

2012



ASHA

AMERICAN STOCK HORSE ASSOCIATION

**Official
Handbook**

www.americanstockhorse.org

FOREWORD

The American Stock Horse Association was chartered as a non-profit organization in 2008. The Association is dedicated to enhancing the pleasure of owning and riding horses through creating better horses and horsemen. The mission of the Association is simple:

Help People Ride a Better Horse

ASHA Animal Welfare Position Statement

The American Stock Horse Association is committed to the humane and proper treatment of all animals. In this respect:

- The welfare of the horse is the primary consideration in all activities
- Horses will be treated with kindness, respect and compassion at all times
- Responsible care will be used by all parties in handling, treatment and transportation of horses
- Horse men and women as owners, exhibitors or trainers will ensure the health and well-being of animals in their care at all times.
- In ASHA classes or activities that involve the use of cattle, ASHA strives to safeguard the welfare of the cattle as well as the welfare of both the horses and riders

The standard by which conduct or treatment will be measured is that which a reasonable person, informed and experienced in generally accepted animal husbandry standard and equine care, training and exhibition procedure would determine to be neither cruel, abusive or inhumane.

Based on these principles, ASHA has developed and enforces rules to ensure ethical competition and humane treatment of horses and cattle. ASHA supports the development of procedures that assure equity, fairness, safety, health and welfare for all participants.

ASHA's Disclaimer of Responsibility for Safety

ASHA does not assume responsibility for safety of participants at clinics and competitions or other events it sanctions.

Safety is a concern of everyone, but ASHA does not assume responsibility for it. ASHA's limited purpose for sanctioning or approving an ASHA event is to promote education and positive fair competition and evaluation. Event management is responsible for participant safety.

American Stock Horse Association

History and Philosophy.

The American Stock Horse Association (ASHA) is an outgrowth of a state-wide planning group from the horse industry in Texas which met in the early 1990's to identify the future needs of the horse industry and to develop programs to meet these future needs. Seven of these individuals, Jack Brainard, Roger Blackmon, Vicki Hoggett, Doug Householder, Bill Jackson, Dennis Sigler and B F Yeates recognized the need for educational programs to ride, train and promote the versatile horse. Affordable and available education was always a priority. The leadership developed programs that met these needs and also brought these philosophies to the national versatile horse movement in other organizations. From the beginning, Texas AgriLife Extension educators such as Bill Jackson, Doug Householder and others helped provide the ground work to move the stock horse versatility philosophy forward. The idea of conducting clinics to ride and train versatile horses as well as holding a clinic preceding every competition was institutionalized. ASHA is meeting these needs today by providing affordable versatile stock horse riding and training clinics as well as competitions to measure the success of the education throughout the United States.

ASHA endeavors to be positive and straight forward – always encouraging growth and improvement. Classes are conducted with an effort to keep a horse as natural as possible while still training him to be correct and precise. The ASHA pleasure class is completely unique. This may be the most important class offered because a good horse must be functional and a pleasure to ride. An important job for a horse is to be a means of transportation to get from one task to another. The trail class measures the horse's ability to handle everyday situations and chores. Obstacles are common sense, everyday encounters and the class is intended to be held on natural terrain. The outside terrain makes the trail class unique and provides horses a different environment from an arena.

The cow horse class is pointed and judged in a more realistic manner than many other cow horse classes offered. The option of either roping or circling is unique and necessary. Everyone loves a good roping horse, but everyone can't rope. Having the option of either roping or circling allows the good roping horse to be showcased, but also allows the non-roper a chance to own a good cow horse. Being able to control a cow without roping is a science as old as roping itself. The reining class is separate from the cow horse class. This is by design and is important because some good horses will work a cow very well, but are not good at all of the maneuvers required in a reining horse and some good reining horses may not work a cow very well.

A horse and/or riders past experience may allow them to compete well in one class while learning to also do another class well. ASHA allows exhibitors to enter one class or all four as their situation changes. ASHA Competitions, with standardized judging and scoring, serve to measure progress and provide an incentive for further improvement. Riders compare maneuver scores from one competition to the next as they strive for improvement. Exhibitors feel as if they are competing against themselves from one evaluation to the next. Participants tend to encourage each other and celebrate their victories. With this program, both rider and horses improve and eventually become very versatile.

The scoring system is a positive one rather than a negative one which, could lead, to many disqualifications. There are very few horses or riders disqualified – this is by design. We believe that a horse and rider should be given credit for what they accomplish rather than disqualified with no score.

These points may not seem significant, but if you look at the many different rules that are being offered today, you will appreciate ASHA rules. ASHA is firmly committed to a positive scoring system and the four separate classes of stock horse pleasure, reining, trail and working cow horse. We recognize that there are many more fun and useful classes in which to show a versatile stock horse. However, in view of time required to conduct a show, we doubt they would measure any feature that is not measured adequately in the four classes that are offered by ASHA.

This handbook contains Corporation By-Laws, General Rule and Regulations and ASHA Event Rules with class descriptions. Note: Rule Changes and Clarifications Effective Jan 1, 2012 are shaded in gray. This Handbook was revised Jan. 1, 2012.

AMERICAN STOCK HORSE ASSOCIATION, INC BYLAWS

These Bylaws (referred to as the “bylaws”) govern the affairs of the AMERICAN STOCK HORSE ASSOCIATION, INC., a nonprofit corporation (referred to as the “Association”) organized under the Texas Non-Profit Corporation Act (referred to as the “Act.”)

ARTICLE I – TITLE, OBJECTIVES, LOCATION AND CORPORATE SEAL

Section 1. Title. This Association shall be known as the American Stock Horse Association, Inc., (“Association”) and shall at all times be operated and conducted as a non-profit corporation in accordance with the laws of the State of Texas, providing for such organizations and by which it shall acquire all such rights as granted to associations of this kind.

Section 2. Objectives. The purpose of this Association shall be to promote education for western stock horse enthusiasts to ride and train a versatile western stock horse, to teach rider knowledge and skills to maximize horse trainability, performance and safety, to offer affordable, fun, and standardized versatile western stock horse educational programs and competitions, to perpetuate and preserve the western tradition and heritage of working stock and ranch horses, to encourage the use of standard rules for conducting and judging contests for the western all-around stock horse, to define, promote and improve the quality of the versatile western stock horse, to encourage honesty, integrity, respect, sportsmanship and family values.

Section 3. Place of Business The principal place of business shall be located in Texas, but the Association’s members or officers may be residents of any state, territory or country, and business may be carried on at any place convenient to such members or officials, as may be participating.

Section 4. Corporate Seal. The seal of the Association shall be in the charge of the Executive Director.

ARTICLE II - MEMBERS

Section 1. Members of the Association shall be admitted, retained, suspended and expelled in accordance with such rules and regulations as the Board of Directors may, from time to time, adopt. In all matters governed by Members, each Member given the right to vote, shall be in good standing and shall have been a paid Member for at least ninety (90) days. Each such Member shall be entitled to one vote

Section 2. Whenever in these Bylaws, the term Member or Members shall be used, unless otherwise specified, it shall mean a Member(s), having the right to vote, that is in good standing.

Section 3. Membership shall be open to all persons who subscribe to the aims of the Association, abide by the Association’s rules and regulations, and assist in furthering its purposes.

Section 4. An annual meeting of the members shall be held at such time and place as may be fixed by the Board of Directors. Notice of the Annual Meeting, including date, time, place, and agenda shall be published in the Association’s publications and on the Association’s website at least 20 days prior to the meeting.

Section 5. Special meetings of Members may be held at such time and place as may be designated in a notice, whenever called, by direction of the President, by a majority of the Board of Directors, or by notice signed by not less than twenty five percent (25%) of Members.

Section 6. At any meeting of the members held in accordance with the foregoing Notice provisions, members attending such meeting shall constitute a quorum for all purposes unless the representation of a large number should be required by law. In that case the representation so required shall constitute a quorum. To vote, a member must be physically present at a meeting. No absentee ballot or proxy votes are allowed.

Section 7. Any officer of the Association may call a meeting of the members to order and may act as chairman of such meeting, precedence being given as follows: President, First Vice-

President and Executive Director.

Section 8. Membership in the Association does not entitle any member to examine, review or copy any information that the Board of Directors deems to be proprietary in nature.

ARTICLE III - DIRECTORS

Section 1. The business and property of the Association shall be managed and controlled by the Board of Directors, which shall elect an Executive Committee hereinafter created and empowered to run the day to day affairs of the Association. The Bylaws and Rules shall be subject to change only by the Board of Directors.

Section 2. The Board of Directors shall be comprised of annually elected directors, current Executive Committee Members, Past ASHA Presidents, Directors-at-Large and Honorary Directors. At least one director on the board must be a representative of an equine educational entity. (This director cannot be a college student to satisfy the requirement and this director may be appointed by the President, with the approval of the Executive Committee, if elections do not include an equine educational entity representative.) The President shall serve as Chairman of the Board.

Section 3. All elected and appointed directors, current Executive Committee Members, Past ASHA Presidents, Directors-at-Large and Honorary Directors shall be voting members of the Board of Directors.

Section 4. It is a privilege, not a right to serve on the Board of Directors. Throughout his/her tenure, a Director must (1) remain an ASHA member in good standing, (2) adhere to ASHA rules and regulations, (3) conduct themselves in an exemplary manner such as to favorably reflect on the Board of Directors and ASHA, its programs, policies, objectives and harmonious relationship of its members. All Directors in any of the director categories agree to abide by ASHA policies and guidelines designed to assist ASHA in complying with state, federal or other applicable law.

Section 5. Each director elected shall be a bona fide resident of the region from which they are elected and no more than two members of any family or firm may sit on the Board of Directors. Persons elected to the Board of Directors must have been members of the Association for two years before taking office and be a current member in good standing. Exception: a person who has been disqualified from their position of Director by non-attendance in the current term is considered ineligible for nomination for two (2) years. No member shall hold a directorship without being at least twenty one (21) years of age. Directors who have distinguished themselves by length of service and/or accomplishments and members who are serving or have served as liaisons to other organizations may be appointed by the President with approval of the Executive Committee as a Director-at-Large or an Honorary Director. All past presidents of the Association shall automatically become a Director-At-Large.

Section 6. The Association shall have approximately 24 elected directors, but the number of elected directors shall be determined, from time to time, by the Board of Directors.

Section 7. The United States shall be divided into geographical regions at the discretion of the Board and set forth in the General Rules of the Association. These geographical regions shall be reviewed annually by the Board and may be changed, from time to time, by the Board according to changes in membership.

Section 8. Each geographical region shall be entitled to regional directors who will also be a member of the Association's Board of Directors and shall be nominated and elected as provided herein. A director shall be elected from a Region when total ASHA membership in that region reaches 200 members and additional directors shall be elected for each additional 200 members. The exact number of members necessary for additional directors may be changed from time to time by the Board of Directors as the total association membership warrants. Membership numbers as of December 31 of the prior year will be used to determine current year director seats available for the Regions.

Section 9. Directors elected at the regular election of directors shall be elected by their regional membership to serve for a term of three (3) years or until their successors are elected and have taken office at the adjournment of the current year Annual Convention Board of Directors meeting. The terms of office shall be staggered so that the terms of one

third of the members of the Board of Directors expire each year. Each director elected shall be a bona fide resident of the Region which they represent.

Section 10. The Honorary Director designation is for directors who have distinguished themselves by length of service and/or accomplishments. Criteria for these Directors shall be established, from time to time by the Executive Committee with approval of the Board of Directors.

Section 11. In case of any vacancy on the Board of Directors by death, resignation, unauthorized absences, disqualification, or other cause, the President, with the advice and consent of the Executive Committee, shall appoint new or additional directors.

Section 12. Each Director, before taking his position, shall disclose in writing to the President, all businesses or other organizations of which he/she is an officer, trustee, shareholder, member, owner or employee or for which he acts as an agent and with which the Association has or might reasonably in the future enter into a relationship or a transaction in which the Director would have conflicting interests. This includes businesses and interests of family members with which the Association might reasonably in the future enter into a relationship or transaction. Also, each Director, before taking his position, shall sign and agree to the Conflict of Interest Policy.

Section 13. A director/alternate must attend one-half (½) of the meetings on a running 12 month period, and answer roll call at the time it is taken to record their attendance. Failing to do this, the director/alternate may be replaced at the discretion of the President.

Section 14. The annual meeting of the Board of Directors shall be held immediately following the annual members' meeting and no notice shall be required for this meeting. The Board, by rule, may provide for other regular meetings at stated time and places, of which no notice shall be required. Absentee or vote by proxy is not allowed in any meeting of the Board of Directors.

Section 15. Special meetings of the Board of Directors shall be held whenever called by the President, or by two-thirds of the directors in office. The Executive Director shall give notice of each special meeting by mailing or telephoning the same to each director at least twenty (20) days before the meeting. But such notice may be waived by any director. Unless otherwise indicated in the notice thereof, any and all business may be transacted at a special meeting. Any business may be transacted at any meeting at which every director may be present, even if the meeting was called without any notice.

Section 16. One half the number plus one of the directors shall constitute a quorum for the transaction of business, but if at any meeting of the Board there may be less than this number present, a majority of those present may adjourn the meeting from time to time until a quorum shall be present.

Section 17. At meetings of the Board of Directors, business shall be transacted in such order as the President may determine.

Section 18. The Board of Directors shall elect officers of the Association at a regular mid-year meeting which the Board, by rule, may provide for at a stated time and place, of which a notice of at least twenty (20) days shall be given.

Section 19. The Board of Directors shall have the power and authority to make, amend, repeal and enforce such rules and regulations, not contrary to law or the Certificate of Formation as they may deem expedient concerning the conduct, management and activities of the Association, the admissions, classification, qualification, suspension and expulsion of members, removal of officers, the rules and regulations governing the procedure of such suspension and expulsion and removal, the fixing and collecting of dues and fees, the expenditure of money, the auditing of books and records, rules regarding awarding of championships and awards, the conducting of clinics, educational programs, seminars, shows, contests, exhibitions, sales and social functions, and all other details relating to the general purposes of the Association.

Section 20. However, actions of the Board of Directors are subject to revision or amendment by the Members at any regular or special meeting of the Members, provided that written notice of any intention to revise or amend any rule or regulation shall have been mailed to all Members at least twenty (20) days in advance of the meeting.

Section 21. The Board of Directors, from time to time, may create and empower committees, general or special. A committee shall have only those powers specifically granted to it by the Board of Directors. At the time a committee is established by the Board of Directors, the Board shall define its responsibilities in writing. In designating powers and responsibilities to committees, the Board shall not entrust any committee with any of the powers and duties specific to the Board.

Section 22. An officer, director, employee, or staff member other than the President and Executive Director, attending an Association approved or sponsored event, shall not attend in any official capacity unless authorized by the Executive Committee.

Section 23. The Board of Directors shall have general charge of the affairs, finances and property of the Association, to which they shall make an annual report to the membership at a general membership meeting.

Section 24. No director of the Association shall be liable to the Association or its members for monetary damages for an act or omission in such director's capacity as a director of the Association except that this Article shall not eliminate or limit the liability of a director of the Association for

- A. A breach of such director's duty of loyalty to the Association or its members.
- B. An act or omission not in good faith or that involves intentional misconduct or a knowing violation of the law
- C. A transaction from which a director received an improper benefit, whether or not the benefit resulted from an action taken within the scope of the director's office or
- D. An act or omission for which the liability of a director is expressly provided for by statute.

Section 25. Any repeal or amendment of this Article by the members of the Association shall be prospective only, and shall not adversely affect any limitation on the personal liability of a director of the Association existing at the time of such repeal or amendment. Anything herein to the contrary notwithstanding, if the Texas Miscellaneous Corporation Laws Act is amended after approval by the members of this Article to authorize corporate action further eliminating or limiting the personal liability of directors, then the liability of a director of the Association shall be eliminated or limited to the fullest extent permitted by the Texas Miscellaneous Corporation Laws Act, as so amended from time to time.

ARTICLE IV - ELECTION OF DIRECTORS.

A Directors Nominating Committee, which must be comprised of elected Directors or Directors-at-Large, separate from the Nominating Committee for Officers and Executive Committee, shall be appointed by the President and be publicly announced by February 1 of each year or as soon as practical thereafter.

1. Recommendations for nominations for Directors will be received by the Directors Nominating Committee.

- a. There may be only one nominee director and alternate per directorship vacancy.
- b. The Director nominating committee shall prepare a ballot, taking into consideration nominations from individual recommendations, director recommendations and recommendations of the nominating committee.
- c. In addition, an individual may recommend him/herself for nomination upon submission of the signatures of ten (10) members, in good standing and residing in the Region as evidence of endorsement of the recommendation.
- d. To be eligible to serve, each nominee, director or alternate shall be a bona fide resident of his Representative area, a current ASHA member in good standing, at least 21 years of age, shall have been a member of the Association for at least two (2) years. Exception: A person who has been disqualified from their position of Director/Alternate by non-attendance in the current term (in accordance with Article III, Section 8) is considered ineligible for nomination for 2 years.
- e. Further eligibility includes accepting the responsibility to : be an ambassador of good will by holding the Association in a positive light to members and the general public at all times, actively participate in Board and Association meetings, accept and carry out specific responsibilities as assigned by the President and/or the Board, act at all times in the best interest of the Association and its members, not in self-interest, exercise good faith in all transactions in exercising their duties to the Association and its property. In addition,

Directors must adhere to a strict rule of honest dealing in all matters with and on behalf of the Association.

2. The recommendations for directors must be mailed to the Association office and bear a postmark date of no later than March 1 of the election year.

3. The Directors Nominating Committee shall prepare a ballot for each representative area and shall mail the ballot to all members in good standing of such representative area. Ballots must be returned according to director election procedures.

4. The nominee(s) will be designated director(s) or alternate(s) according to the number of votes received for each nominee on the ballot. The nominee(s) receiving the highest number(s) of votes will be designated director(s) after which the alternate(s) will be designated according to the remaining number of votes in descending order for positions needed, if applicable. Each area will be allowed one (1) alternate to serve for one (1) year. If an area is entitled to an alternate only, the nominee receiving the highest number of votes will be named alternate for a Representative Area.

5. When there are fewer nominees on the ballot than needed for the director and/or alternate position in a Representative Area, the President, with the advice and consent of the Executive Committee, may appoint the unfilled position(s) for that Representative Area.

6. Alternates will be appointed to standing committees with full voting privileges therein, but would only have director voting privileges in the absence of a director from their Representative Area.

7. The Board of Directors for the coming year shall be determined by June 1 of the election year or as soon as practical thereafter. Directors shall take office upon installation of officers at the Annual Convention.

ARTICLE V - EXECUTIVE COMMITTEE

Section 1. There shall be an Executive Committee consisting of the President, First Vice-President, Second Vice-President, the Immediate Past President, and two additional members. These officers and additional executive committee members shall be elected by and from the current Board of Directors, at the annual meeting of the board, each for a term of one year and until the selection and qualification of his/her successor.

Section 2. The Executive Committee members will continue to be voting members of the Board of Directors as long as they are re-elected to the Executive Committee.

Section 3. The President shall appoint and publicly announce a Nominating Committee for Officers and the Executive Committee, which must be comprised of elected Directors, or Directors-at-Large, by May 1 of the election year or as soon as practical thereafter. Their nominations shall be published on the Association's website

Section 4. The President with the advice and consent of the Executive Committee shall fill all vacancies in the Executive Committee occurring between annual meetings of the Association.

Section 5. Unless otherwise specified in any employment contract approved by the Executive Committee, the executive committee members of the Association shall hold office for a period of one(1) year or until their successors are elected and have taken office at the Annual Meeting.

Section 6. No officer or member of the Executive Committee, with the exception of the Executive Director, may serve on the Executive Committee in excess of 6 consecutive years.

Section 7. The Executive Committee shall meet whenever and wherever called by direction of the President or three members of the Committee acting jointly, of which meeting, the Executive Director shall give 10 days' written notice, but such notice may be waived by a member. Absentee or vote by proxy is not allowed in any meeting of the Executive Committee.

Section 8. The Committee may act, without convening in meeting, by written resolutions signed by all Members thereof. Members of the Committee may participate in a meeting through use of conference telephone, electronic video screen communications, or other communications equipment provided all members participating in the meeting are able to hear one another. Records of the meeting and decisions by written resolution and/or electronic means shall be duly entered in the Association records.

Section 9. All powers of the Board of Directors are hereby vested in the Executive Committee. All actions of the Executive Committee with the exception of disciplinary actions

resulting from hearings are subject to ratification, revision or amendment by the directors at any regular or special meeting of the Directors.

Section 10. It shall be the responsibility of the Executive Committee to direct all Association business matters, to furnish liaison members to the Standing Committees, to report to the Board of Directors at its regular meetings, to interview persons for the position of Executive Director and employ a person as Executive Director.

Section 11. The Executive Committee shall be responsible for interpreting and deciding all questions or ambiguities that may arise in connection with the meaning, intent or purpose of any by-law, rule, regulation or other Association document.

Section 12. One half the number plus one of the executive committee shall constitute a quorum for the legal transaction of business, but if at any meeting of the Committee there may be less than this number present, a majority of those present may adjourn the meeting from time to time until a quorum shall be present.

Section 13. The written contracts of the Association shall be executed on behalf of the Association by the President and/or the Executive Director upon approval by the Executive Committee.

Section 14. All vacancies of the officers of the Association, except where provided elsewhere, shall be filled by and from the Executive Committee for the unexpired term and those so appointed shall serve until the election and acceptance of their duly qualified successors.

Section 15. Should a member of the Executive Committee fail to be re-elected to the Executive Committee, he/she must be nominated as prescribed in the Bylaws and run for an open Directors position, if available, as prescribed in Article III.

ARTICLE VI - OFFICERS & DUTIES

Section 1. The Officers of the Association shall be the President, First Vice-President, Second Vice- President, Executive Director and such other officers as may be authorized from time to time by the Board of Directors.

Section 2. Only members of the Board of Directors shall be eligible to serve as officers of the Association. The President must be elected from the current Executive Committee. The Executive Director need not have been a member of the Board of Directors.

Section 3. The officers of the Association shall be elected by majority vote by the Board of Directors. Anything herein to the contrary notwithstanding, the Executive Director shall not be elected by the Board of Directors, but shall be employed by the Executive Committee, with the approval of the Board of Directors.

Section 4. Unless otherwise specified in any employment contract approved by the Board of Directors, the officers of the Association shall hold office for a period of one (1) year or until their successors are elected and have taken office at the Annual Meeting.

Section 5. Duties of Elected Officers:

A. **PRESIDENT:** The President shall be the Chief Executive Officer of the Association and shall preside at all meetings of the Board of Directors and the Executive Committee. The President shall see that the Bylaws, and Rules and Regulations of the Association are enforced and shall perform all other duties that may be prescribed from time to time by the Board of Directors. The President shall be an ex-officio member of all committees.

B. **FIRST VICE-PRESIDENT:** In the absence of the President, The First Vice-President shall have the powers and perform the duties of the President. The First Vice-President shall be Chairman of a Committee specified by the Board of Directors, and perform other duties as may be prescribed by the Board of Directors.

C. **SECOND VICE-PRESIDENT:** In the absence of the President and the First Vice-President, the Second Vice-President shall have the powers and perform the duties of the President. The Second Vice- President shall be Chairman of a Committee specified by the Board of Directors, and perform other duties as may be prescribed by the Board of Directors.

D. **VICE-PRESIDENT-TAX:** The Vice-President - Tax shall have the powers and to advise the Corporation with respect to federal and state tax matters, to secure tax-exempt status for the Corporation, and to perform the other duties as may be prescribed by the Executive Director or the Board of Directors.

D. **EXECUTIVE DIRECTOR:** In the event, the Executive Committee retains a person or qualified firm to be Executive Director of the Association, this person will perform the function

for a contract term not to exceed three (3) years, with provision of termination for cause. The contract may be renewed by the Executive Committee for successive three-year periods. The duties, functions and remuneration for the position of Executive Director will be dictated by the Board of Directors. The Executive Director is the chief operating officer of the Association, and pursuant to direction of the Executive Committee, shall implement the actions, decisions and directions of the Board of Directors and Executive Committee; and shall manage the Associations physical facilities and personnel. The Executive Director shall keep the minutes of all membership and Directors meetings, shall be the custodian for the safekeeping of all documents and records of the Association, shall collect all monies due the Association, shall disburse the money of the Association; however, only upon itemized demands and upon the order of the Executive Committee. The Executive Director shall account for all of the same by itemized statements in detail to each annual meeting of the members and the Board of Directors when demanded. Also, the Executive Director shall cause to be submitted to the Executive Committee, a detailed budget of the proposed and anticipated expenditures for the forthcoming fiscal year of the Association. Upon approval of this said budget, or its modification, it becomes binding upon the officers of the Association and cannot be exceeded in the total amount set forth by more than ten percent without a majority vote of the Executive Committee. The Executive Director shall be ex officio member of all committees appointed by the President or Board of Directors. The Executive Director shall make a report of his office to the Board of Directors when demanded and at all annual membership meetings and shall perform such other duties as may be prescribed by the Board of Directors from time to time.

Section 6. The Association shall conduct its affairs on a calendar year basis. A financial audit shall be made and be reported to the next annual meeting of the members. The Executive Director and all other officers or employees of the Association who may handle any funds of the Association shall give a surety bond to be furnished at the expense of the Association for the faithful discharge of his or her duties if so required by the Executive Committee

ARTICLE VII - PARLIAMENTARY AUTHORITY

The rules contained in the current edition of Roberts Rules of Order, Newly Revised shall govern the Association in all cases to which they are applicable and in which they are not inconsistent with these bylaws and any special rules of order the Association may adopt.

ARTICLE VIII - DISSOLUTION

Upon the dissolution of the Association, the Board of Directors shall, after paying or making provision for the payment of all the liabilities of the Association, dispose of all the Assets of the Association exclusively for the purposes of the Association in such manner, or to such organization or organizations organized and operated exclusively for charitable, educational, religious or scientific purposes as shall at the time qualify as an exempt organization or organizations under Section 501(c)(3) or 501(c)(5) of the Internal Revenue Code of 1986 or the corresponding provision of any future United States Internal Revenue Law, as the Board of Directors shall determine. Any of such assets not so disposed of shall be disposed by the Court of Common Pleas of the county exclusively for such purpose or to such organization or organizations of said court determines, which are organized or operated exclusively for such purposes

ARTICLE IX - RULES

The Board of Directors is responsible for establishing the rules consonant with and supplementary to the Constitution and Bylaws for the general administration of the business of the Association. The rules shall be published by the members of the Board, with revisions published when sufficient changes to the rules warrant a new publication.

ARTICLE X – AMENDMENTS

The Board of Directors shall have the power to make, amend and repeal the Bylaws of the Association by vote of the majority of the Directors at any regular or special meeting of the Board, subject to the right of the members to rescind or amend any such Bylaws in the same manner as provided in Section 14, Article III.

ARTICLE XI - RECALL

Any member of the Executive Committee may be removed from office with or without cause as herein provided. A recall petition demanding the removal of such officers shall be submitted to the Executive Director of the Association. Such recall petition(s) shall be signed

by at least twenty-five percent (25% of the current members of the Board of Directors, and the recall shall be effective when delivered to the Executive Director.

ARTICLE XII - INDEMNIFICATION

The Association shall indemnify and hold harmless any Officer, Director, Past President, Director-at-Large, and employee of the Association, their personal representatives and heirs, against reasonable legal expense, judgments and expense of settlement that the Association previously approved, actually and reasonably incurred in connection with an actual or threatened legal proceeding, if such person acted legally, in good faith, and was duly authorized to act on behalf of the Association. In the transaction from which legal liability arose, which was official Association business, except in relation to matters as to which he shall have been guilty of negligence or misconduct in respect of the matter in which indemnity is sought. To preserve this right of indemnity, such person shall immediately notify the Association of such actual or threatened litigation, whereupon, the Association shall have the right to direct defense thereof, including, but not limited to, selection of counsel, and direction of settlement negotiations, with the privilege of consent to the selection of counsel to be allowed the indemnified which consent will not be unreasonably withheld.

ARTICLE XIII - AFFILIATES

Section 1. Affiliates shall be chartered and operate under the supervision of the ASHA Board of Directors. **Each affiliate must apply for ASHA affiliation by completing the Affiliate application form. The application will be reviewed by an ASHA Board of Directors Affiliate committee with recommendations sent to the total board of directors for approval, disapproval or revisions.** Additionally the affiliate must also send to the Association annual dues and reports as set by the Board and otherwise comply with the ASHA Rules and Regulations. **Failure to enforce ASHA Rules and Regulations and the Affiliate Rules and Regulations that are annually approved by ASHA may result in the review and/or revoking of an affiliate's status.**

Section 2. Affiliation is a privilege, not a vested right, granted or rejected at the American Stock Horse Association's discretion on an annual basis according to procedures and requirements formulated by the ASHA **Affiliate Committee and approved by** the Board of Directors. The affiliate association shall, in no manner, have authority, express or implied, to act for, or bind the American Stock Horse Association in any manner. Final approval/denial of charter applications rest solely with the **Board of Directors.**

Section 3. An affiliate must be formed as a non-profit corporation with articles of incorporation and bylaws prepared accordingly to the controlling laws of the state of incorporation and governed by its own Articles of Incorporation and Bylaws

Section 4. Each Affiliate must conform to the state laws of incorporation in which they are organized and be consistent with the ASHA Bylaws and rules. Affiliates must follow standard procedures as set forth by the ASHA and must revise/amend their bylaws and rules as the ASHA Bylaws and rules are revised/amended.

A. Affiliates must be formed and maintained only for the purpose of advancing and promoting education and the versatile stock horse through the ideals of ASHA, including good horsemanship and good sportsmanship and should consist of a "purpose" which states "to cooperate with and aid in every way possible the programs and functions of the ASHA and to uphold the policies of the ASHA"

B. Affiliate By-Laws shall include but are not limited to the following:

1. Name, location, purposes and corporate seal
2. Geographic Boundaries
3. Membership, annual membership meetings and quorum
4. Board of Directors and duties of the board - the by-laws must state: "The Board of Directors shall consist of members elected by the membership with at least one director being a representative of an equine educational entity. (This director cannot be a college student to satisfy the requirement and this director may be appointed by the President, with the approval of the Executive Committee, if the election does not include an equine educational entity representative.)"
5. Officers and duties of the Officers including regular financial accounting
6. Annual Election of Directors and Officers

7. Amendments
8. Indemnification, and
9. Dissolution

Section 5. Any group desiring to charter an affiliate should obtain an application for affiliation from the Association that shall contain step by step instructions on how to proceed with the petition of charter for affiliate status including charter and annual fees. Affiliates must have and maintain a minimum of twenty (20) ASHA members, in good standing.

A. Applications for charters and renewals shall be reviewed by the ASHA Board of Directors Affiliate Committee, which shall meet monthly, with recommendations for approval/denial being forwarded to the Board of Directors. Final approval/denial of charter applications and renewals rest solely with the Board of Directors.

B. No affiliate shall receive final approval until thirty (30) days after the name and location of the proposed affiliate has been published.

Section 6. In a state or **geographical area**, where an affiliate currently exists, a new affiliate may not be chartered without consent from the ASHA Board of Directors. Upon receipt of an application for a new affiliate in a state **or geographical area** where an affiliate currently exists, ASHA will notify all existing affiliates in that area and solicit input regarding such application. The ASHA Board of Directors will decide, based on the best interest of ASHA whether any new affiliates will be chartered. **All due diligence will be taken so that adverse effects on an existing affiliate will be minimum.**

Section 7. Once a charter is granted to an affiliate, it is renewed annually upon receipt of an acceptable affiliate annual report and renewal fees. Specific annual requirements and activity levels shall include but are not limited to the following.

- A. Payment of annual fee
- B. Membership maintained of at least twenty (20) ASHA members, in good standing.
- C. Submitting of current affiliate by-laws
- D. Submitting of previous year's annual financial statement including a listing of all income and expenditures
- E. **Report of affiliate activities and ASHA approved events**
- F. Conducting its affairs in compliance with the Bylaws and standing rules of this association including, but not limited to the annual election of Officers and Directors
- G. Use of due process in all matters of discipline of suspension of its members
- H. Review of Affiliate handling of all reports and results of all sanctioned ASHA events during previous year

Section 8. Failure to meet and maintain the specific requirements and minimal activity levels necessary for maintaining an affiliate charter may result in the revocation of the affiliate charter by the **Board of Directors**. Failure to respond to the ASHA request for information/corrections within ninety (90) days of the written notice will result in request for future ASHA Events being denied until said information has been received. Failure to respond to the ASHA second request of information within ninety (90) days of the written request may result in the **Affiliate Committee's** recommendations to the **Board of Directors** to revoke the affiliate charter.

General Rules and Regulations

GR - 010 Geographical Regions

The membership of the Association shall be divided into the geographical territories and regions set forth below:

Region 1-Texas

Region 2- Alabama, Arkansas, Georgia, Florida, Louisiana, Mississippi, North Carolina, South Carolina, Tennessee

Region 3- Illinois, Indiana, Iowa, Kentucky, Michigan, Minnesota, Missouri, Ohio, Wisconsin

Region 4- Connecticut, Delaware, Maine, Maryland, Massachusetts, New Hampshire, New Jersey, Pennsylvania, New York, Rhode Island, Vermont, Virginia, West Virginia,

Region 5 - Colorado, Kansas, Montana, Nebraska, New Mexico, North Dakota, Oklahoma, South Dakota, Wyoming

Region 6 - Alaska, Arizona, California, Hawaii, Idaho, Nevada, Oregon, Utah, Washington
GR - 020 STANDING COMMITTEES

- A.** All Standing Committees shall consist of not less than two Association members and not more than ten. Committee members must be Association members in good standing. In making appointments to the committees, the President shall appoint committee members for not less than one year, and not more than three years. Future appointments to fill vacancies and for new members shall be by the President with the advice and consent of the Executive Committee
- B** The Chairperson of each committee shall be appointed annually by the President from the current Board of Directors. Committee members may be appointed from the Board of Directors and the general membership and a listing of all committee members shall be published as soon as possible after appointment.
- C.** These committees shall have those duties as prescribed or granted to them by the Executive Committee. Committees shall advise the Executive Committee & Board of Directors on matters relative to their committee assignments. They also will evaluate their program area, prioritize needs, make proposed annual and/or long range plans, and present these findings to the Executive Committee. The report and plans will be approved or disapproved for action during the year or year(s).
- D.** Subsequently each Committee has the authority to carry out their approved plans within limits set up by Executive Committee and Board of Directors. Timely reports of committee projects and actions shall be given to the Board of Directors.
- E.** Standing Committees may be, but not limited to:
Affiliates, Budget and Finance, Classification, Collegiate Activities, Communications, Education, Futurity, Marketing and Development, Rules and Regulations, Sponsorships, Shows, Contests and Recognition, Youth Activities, ,
These committees serve for the duration of a special project or program or until replaced or until the committee is disbanded.

GR-030 Proposed Rule Change

- An Association member, a standing committee, a special committee, the Board of Directors, the Executive Committee or the Association staff may propose a rule change. A Rule change is any change to the Bylaws or Rules.
1. All proposed changes must be submitted on the form designated for that purpose and available free of charge from the Association Office. All blanks must be completed and a justification for the proposed change cited. Forms which are incomplete, lacking the justification, or failing to cite the specific change requested, will be returned to the originator.
 2. A proposed rule change form should be sent to the Association office by March 1 of each year for consideration in the current year. .
 3. All Proposed Procedural Changes will be
 - 1) Researched and reviewed by Association Office Staff, Budget and Finance Committee, Executive Committee and the Association Attorney, if deemed necessary. A proposed Rule Change that contains possible legal or financial implication or any consequences deemed not in the best interest of the Association may be subject to action by the Executive Committee. If tabled by the Executive Committee, the proposed change will be returned to the originator with comments from the reviewers. If deemed appropriate for further study, the proposed change will be referred to the appropriate Standing Committee Chairmen and the Rules Committee.
 - 2) Referred to the appropriate Standing Committee(s) Chairmen and the Rules and Regulations Committee.
 - 3) Referred back to the Executive Committee from the standing committee(s) chairmen and/or rules committee with a report and recommendations. If the proposed change is still deemed advantageous to the Association by the Executive Committee the proposed change will be presented for consideration to the Board of Directors.
 - 4) Presented to the Board of Directors in a legal and properly worded form for consideration on the agenda of the next Board of Directors meeting.
 - 5) The Board of Directors will vote on the proposed change.
 - 6) Emergency Status of Proposed Change.

A. If a proposed Rule Change is considered to be of such extreme importance by the Executive Committee that it must be acted upon immediately, such proposed change must be presented to the Board of Directors and is subject to amendment. The emergency status of the proposed change should then be put to a vote by the Board of Directors. The emergency status must first be approved and requires a motion and majority vote in favor.

B. If the Board of Directors approved the Emergency Status, the proposed change with any amendments attached shall then be put to a vote by the Board of Directors for immediate action and/or implementation. If approved, the Change can become effective immediately. If the Emergency Status of the proposed Change is rejected by the Board of Directors, the proposed change itself cannot be put to vote at this time but can still be presented for a vote by the regular procedure.

GR-050 Membership

Membership in the American Stock Horse Association is a privilege not a right. Memberships shall consist of two general categories, Annual and Life memberships. Proper receipts and membership cards shall be issued upon payment of fees.

1. As reciprocal assistance to the Association for privilege of membership and participation, the Association may use any photograph or other form of likeness reproductions of a member, event participant, horse owner, or their horse and registered horse names to promote the Association's objectives and activities including, but not limited to, use by third parties with authorization from the Association.

2. The application for membership should indicate clearly the name (limited to 30 spaces) in which the membership is to be recorded. By applying for membership the applicant automatically agrees to be bound by and to abide by all rules, regulations and policies of the Association.

3. Termination or application rejection proceedings shall be conducted under the Association's disciplinary procedure for notice, hearing and temporary suspension. The effect of termination or rejection may be denial of the privileges of the Association as set forth in the Association's disciplinary procedure.

4. A membership fee is not refundable.

5. Upon completion and acceptance of a membership application form, an applicant is issued a membership card with an identification number. This number must be used in all official communication with the Association and the card must be presented when participating in Association approved events.

6.. Types of Membership

A. ANNUAL MEMBERSHIPS – Membership is available for individuals for a one year period beginning with the first day of month of purchase (based on postmark, postal meters are not acceptable) and expiring the last day of December of that year. Renewal notice to the members shall be sent to their last known address not less than 60 days prior to the end of the calendar year. When an annual membership expires, the membership can be reinstated by simply paying the current year's annual fee. Memberships may only be issued to individuals and may not be transferred. The following designations of annual membership in the Association are currently available. An individual membership is restricted to one person, carried in that person's legal name only.

1 ADULT ANNUAL MEMBERSHIP

An annual membership for persons 19 years and older provides privileges of participating in all Association events and activities.

2. YOUTH ANNUAL MEMBERSHIP

A youth membership is provided for boys and girls age 8 to 18, as of January 1 of the current year, which entitles a youth to receive a membership card of eligibility to show in the youth division, and to participate in Association events and activities. Youth may not vote or hold office in the Association.

3 COLLEGIATE ANNUAL MEMBERSHIPS

A collegiate membership is provided for students enrolled in colleges and universities which entitle a student to receive a membership card of eligibility to show in the collegiate division, and to participate in Association events and activities. Students

may not vote or hold office in the Association.

B. LIFE MEMBERSHIP

A life membership entitles the recipient to receive a life membership card, a certificate and to obtain any Association services at the member rate for the lifetime of the individual. Life memberships may only be issued to individuals and may not be transferred.

C. MEMBERSHIP FEES – The annual membership fee is \$25.00 per individual for adult and youth memberships and \$15.00 for collegiate membership. The life membership fee is a one-time fee of \$250

GR 040. Collegiate Program

A. At this time the American Stock Horse Association Collegiate Program is under the direction of the Association's Collegiate Standing Committee whose chairman shall be a member of the Board of Directors.

B. College students must be a member of this Association to participate in Association sanctioned events.

C. College students will be eligible to serve on the Collegiate Programs Committee.

D. College students are eligible to participate in any Association event as well as specific events planned just for collegiate members.

E. Upon request, the regular Association Show Secretaries will compile results of collegiate entries within regular Association Show Events allowing a collegiate show within a regular Association Show. Placings and awards for Collegiate Show participants will be posted and announced.

F. In addition to regular approved Association clinics and competitions, the Collegiate Programs Committee must apply to the Association for approval for events designed specifically for and limited to collegiate members. Applications to host and/or sponsor special collegiate events must be received in the Association office at least 90 days prior to the event.

G. Results of all Association Collegiate Events must be received in the Association's office within two weeks after the event. Results will be made available on the Association's website and year end totals will be tabulated, distributed and posted on the website.

H. Announcements and Results of the Association's Collegiate Events will be posted on the Association's website as well as included in other Association publicity such as newsletters and press releases.

I. Special awards and recognition may be presented to Collegiate Members at the Associations' Annual Meeting and Banquet.

J. College students will have the opportunity to serve as interns and participate in special educational projects that will benefit both the association and the member.

GR-042 Goals and Special Guidelines for Conducting ASHA Collegiate Activities

ASHA Collegiate Program Goals:

- 1) To promote education of horsemen in the safety, care and training of the versatile stock horse
- 2) To enhance the education of college students interested in the versatile stock horse
- 3) To use the horse as a means to teach students how to represent themselves with responsibility, character and teamwork

A. In order to achieve these goals, Colleges and Universities in the United States will be encouraged to gain approval to offer stock horse horsemanship classes, provide students instruction on riding and training a versatile stock horse, ASHA classes, and be encouraged to participate in ASHA approved events and competitions. Colleges and Universities will be encouraged to select and recognize official college or university stock horse teams to represent them in ASHA Collegiate Competitions. Colleges and Universities will also be allowed to certify Individual Collegiate students to enter as individuals. In order to compete in ASHA Collegiate Stock Horse Competitions, each student must be a current ASHA member and their horse must have an ASHA Competition License.

- 1) Collegiate teams will compete in three divisions of an ASHA Collegiate Show: Open/Non-Pro, Limited Non Pro and Novice
- 2) Individual Collegiate Members may also compete in an ASHA Collegiate Show in these divisions

- 3) A college or university may enter more than one team and an unlimited number of individuals in ASHA Collegiate competitions.
- 4) ASHA Collegiate Stock Horse Teams and Collegiate Individuals must meet the following eligibility requirements:
- Undergraduates must be enrolled in a minimum of 10 hours of classes and graduate students in a minimum of 9 hours. Graduating students may enroll in fewer hours during the semester of graduation.
 - Students must be in good academic standing with their school.
 - Students will be limited to 4 years of collegiate eligibility to compete, including both graduate and undergraduate years.
 - Any questions or disputes about eligibility should be directed to the Collegiate Committee of the ASHA Board of Directors.

5) ASHA Collegiate Members Eligibility for Divisions

Any college or university student who can furnish proof of meeting the eligibility requirements may compete in an ASHA Collegiate show whether their college has a team or not. Collegiate students must present their current ASHA Collegiate membership card or present documentation of their collegiate status and academic standing to the secretary of the show at time of entry. Coaches may certify students on their membership forms if the student has a college coach. An applicant for a Collegiate membership should accurately mark the ASHA divisions - Open, Non-Pro, and Novice for which they are eligible. Coaches must abide by these eligibility requirements when placing Collegiate members on a team.

B. In order to achieve these goals, ASHA will provide leadership and coordination and publicize the ASHA Collegiate program, approve clinics and competitions and keep ASHA Collegiate Show Results in the Official ASHA Records and on the ASHA website.

1) Collegiate Competitions

a) ASHA will approve official ASHA Collegiate Shows that will be open to collegiate members only and that will offer an ASHA Collegiate Stock Horse Team Competition

b) ASHA will approve special ASHA College Team Tournaments as may be decided by participating coaches and the ASHA Collegiate Committee with special awards. Special Collegiate Team Tournament Competitions will not count for Regional Team Awards. Special conditions may alter the number of team members and the specific division(s) offered.

c) ASHA may also approve an official ASHA Collegiate Show within a regular ASHA competition. These will count as a separate show and must be approved, announced and publicized as such. At these Collegiate shows within a regular show, the Collegiate divisions of Non Pro, LTD Non Pro and Novice must be offered. No Open Collegiate Riders will be allowed to show in the Collegiate Division at a regular ASHA Show or Collegiate points kept for this rider, but this open rider may show as an individual in the regular ASHA show Open or Green Horse Division with all required fees. Collegiate points will be awarded based on the number of collegiate competitors in each division and collegiate exhibitors will be eligible for individual Collegiate Show awards. The team awards will be based on the scoring system as described in GR-045.

GR-044 Description of ASHA Collegiate STOCK HORSE TEAMS

An ASHA Collegiate stock horse team shall consist of six members and shall consist of two designated representatives in each of the divisions of Non-Pro/Open, Limited Non Pro and Novice.

- Two (2) Non-Pro/Open
- Two (2) Limited Non-Pro
- Two (2) Novice

Exception: In an ASHA Collegiate Show within a regular ASHA show, no open collegiate riders may compete on a college team.

A school may enter a team with less than 6 members as its representative, but teams with less than four members will not be eligible for Team Awards. Each team member must ride a different horse.

GR-045 Calculation of Points for Collegiate team riders and teams

Points in each class in each division are calculated on the total number of collegiate teams represented, not on the number of total class entries or collegiate individual entries. Example: With 6 teams represented, there will be twelve college team point riders in each class in each division. The highest points a team rider can earn in each class is 12. The points would be 1-12. When teams have less than six and four or more members, there STILL WILL BE TWELVE POINTS to be earned in each class in each division. If one team has only one non-pro point rider leaving only 11 point riders in the class, the highest placing rider in the division STILL receives 12 points, not 11. The team with only one non-pro point rider receives that rider's points and a zero for its other "point rider" for the total team points in that class and division. The point distribution in this case is 12, 11, 10, 9, 8, 7, 6, 5, 4, 3, 2, and 0. Incomplete teams with at least four members shall be eligible for team awards if their team totals exceed those of teams having complete teams.

In the event of a tie between teams, the tie will be broken on the basis of most first place class wins and then on points won in the working cow horse class, reining class, trail class and then pleasure class.

GR-046 ASHA Collegiate Competition Awards

A. ASHA COLLEGIATE INDIVIDUAL CLASS AWARDS: Individual awards are based on the total number of COLLEGIATE riders per class. All ASHA collegiate members entered in the collegiate competition are eligible for individual class awards.

B. ASHA COLLEGIATE INDIVIDUAL ALL-ROUND AWARDS: To be eligible for all-round awards, a collegiate rider must compete in all four classes within the division. Awards are based on points from all 4 classes within the division earned on the basis of total number of COLLEGIATE riders.

C. ASHA COLLEGIATE TEAM AWARDS:

1) Both a High Point and Reserve High Point Team Award will be given if at least three teams from different colleges or universities competing are entered. No ASHA Collegiate team awards will be given when there are less than three different colleges or universities competing.

2) For Collegiate Team awards, each team will be allowed to utilize points from two riders per ASHA division (Open/Non Pro, Limited Non Pro and Novice) and these point riders will be determined at the time of entry by their coach(s) Only the points that these two riders earned against other point riders in their division will be counted towards naming a champion and reserve champion collegiate stock horse team of the competition.

GR 060 TELEVISION AND MEDIA RULES

A. Attendance at an Association sponsored or approved event, in whatever capacity, shall constitute authorization for the Association, its agents, designees, or assigns to photograph, video tape, televise, or record by other means (hereinafter referred to as "photographic material") any person or animal on the premises of an Association-approved event, and shall further constitute authorization for the use of such person's name, voice and biography, or the name, pedigree and performance record of any animal on the premises (hereinafter referred to as "related information") in conjunction with any photographic material.

B/ The photographic material and related information referred to above may be used in any manner that the Association, in its sole discretion, determines would be beneficial to promoting the purposes and goals of the Association, provided, however, that no photographic material or related information will be used in conjunction with the endorsement of any product unless prior written consent is obtained.

C. Attendance at an Association approved event shall further constitute agreement to the terms and conditions outlined above, and shall constitute a waiver and release, without limitation, of any individual television, radio, motion picture, photographic or other similar

rights, including right of privacy, any person or animal may have in or to such photographic material or related information when such information is obtained at an Association approved event by the Association, its agents, designees or assigns.

D. An Association member, including a member using Association data for commercial purposes, has a duty to preserve and protect the performance records and the property of the Association, including, but not limited to, Association electronic data made available to members via the Association's website or other prearranged consensual access thereto, and the duty to use such data only for the purposes which the Association has granted conditional license. Publication of such data shall carry the following designation. "This information was provided by the American Stock Horse Association from its Official Records."

GR- 070 SAFETY AT ASSOCIATION EVENTS

A. Any unmanageable horse will be asked to leave the grounds. This applies to all horses, but especially to stallions.

B. Any competitor or clinic participant riding a horse that is out of control will be asked to leave the premises.

C. In the case of a fallen horse or rider, the judge will blow the whistle and all activity will cease and horse and rider will be inspected for injuries.

D. In the case of equipment failure that could result in an accident, the judge will blow the whistle to stop all activity and management will provide assistance where needed.

E. Judges will have the authority to blow a whistle at any time to stop and or excuse any exhibitor who is not in control of their horse.

F. In classes that involve the use of cattle, the Association strives to safeguard the welfare of the cattle, as well as the welfare of both the horses and riders competing in the class. Association Events are encouraged to provide proper equipment and medication should accidental injury occur.

GR - 080. RELEASE OF LIABILITY

A. The Association and co-sponsoring organizations, if any, shall not be responsible for any personal injury, or for loss or damage to property, occurring at any Association activity. Each owner, exhibitor, handler, or consignor shall indemnify and hold harmless the Association, its officers, directors and employees from and against all claims, demands, causes of actions, and expenses of every kind, including attorney's fees, arising out of or related in any manner to the acts or omissions of an owner, exhibitor, handler, or consignor, or the actions of any animal under the care, custody or control of the owner, exhibitor, handler or consignor. Presentation of signed entry or consignment forms shall be deemed acceptance of the conditions of this rule. In the event an entry or consignment form is not signed or presented, appearance on the grounds or at the sale ring of any Association activity as an exhibitor, handler, owner, or consignor shall be deemed to be acceptance of the conditions of this rule.

B. Disclaimer of Responsibility for Safety of Show or Event Participants.

1) Show/event management is responsible for the condition of show/event premises, including arena and exercise areas, the conduct and competence of show/event employees and other representatives, implementation of show/event activities and events, and all other aspects of an Association approved show/event

2) The Association does not assume or accept duty or responsibility for safety at this show/event in regard to participants or any other third parties, or for the horses or other property thereof.

3) As an express condition of the privilege to participate at an Association approved or sponsored show or event, each owner of a horse, exhibitor, trainer, participants, assume the risks of participation and release and discharge the Association, its officers, directors, representatives and employees from any and all liability, whenever or however arising as to personal injury or property damage, occurring as a result of participation in a show/event conducted by the show/event or on the show/event grounds thereof.

C. Without assuming the affirmative duty to monitor possible physical or mental handicaps of exhibitors, if condition of exhibitors' physical or mental disability comes to

the attention of the Association, the individual may be denied participation privileges in Association approved events until such time as he or she provides the Association with sufficient information to conclusively establish physical or mental capability to participate, without posing a significant risk to the health or safety of the individual and/or the other exhibitors of the class in which he or she desires to participate. At Association's sole discretion, the individual may be authorized to use special equipment to enhance physical ability to safely exhibit in Association approved or sponsored shows/events.

GR - 083 EXHIBITOR CONDUCT

A. No exhibitor shall approach a judge during an ASHA competition except through a show official. An exhibitor may make a request through a show official for a judge's opinion or interpretation which can be stated in the presence of a show official at any time.; however, at no time should interaction between the exhibitor and the judge be permitted during a competition

B. Conduct by Association members, non- members, exhibitors, trainers, owners, owner's representatives, spectators, and all other persons present on the Association event grounds of facilities shall be orderly, responsible, sportsmanlike, and humane in the treatment of horses. Any of these violations will be subject to disciplinary procedures.

GR - 084 INHUMANE TREATMENT

No person may treat a horse in an inhumane manner which includes, but is not limited to:

A. Placing an object in a horse's mouth so as to cause undue discomfort or distress.

B. Tying a horse in a manner as to cause undue discomfort or distress including but not limited to in a stall, trailer or when longeing or riding.

C. Use of inhumane training techniques or methods, poling or striking horses legs with objects (i.e. tack poles, jump poles, etc.)

D. Use of inhumane equipment, including, but not limited to, saw tooth bits, hock hobbles, tack collars or tack hackamores

E. Any item or appliance that restricts the movement or circulation of the tail, or intentional inhumane treatment which results in bleeding

GR - 086 DRUGS AND MEDICATION

The use of any stimulants or depressants is prohibited. Any surgical procedure or drug that could affect a horse's performance or alter its natural conformation is prohibited. (Butazolidin use is legal.)

GR - 090 DISCIPLINARY PROCEDURES

The Association reserves the right to independently direct disciplinary action or sanction against individuals coming under the jurisdiction by participating in Association sponsored events. The Association Executive Committee is the forum within the Association that initially or ultimately hears or reviews evidence of alleged violations of rules and regulations by members and/or participants in Association approved events. A member may be disciplined, suspended, fined, and/or expelled from the Association and any non-member participant may be denied any or all Association privileges.

GR - 095 VIOLATIONS

A. Financial Violations – Any member may be suspended and denied privileges of the Association or any nonmember may be denied the privilege of the Association by the Executive Committee of the Association, for the failure to pay, when due, any obligation owing the Association. Upon receipt of a fraudulent payment, a member or nonmember will be notified in writing and given a reasonable amount of time to make the payment good. Failure to pay the owed amount to the Association or its sponsoring groups will result in suspension of membership and all privileges. Repeat offenders will be put on a cash only basis.

GR – 100 HORSE COMPETITION LICENSING RULES AND REGULATIONS

A. The goal of ASHA in providing competition licenses for horses competing in ASHA competitions is to accurately record performance records of both horses and riders and reward these horse/rider combinations on the achievements that they earn. Competition licenses are used to keep an accurate and consistent record on each horse.

B. All horses competing in ASHA approved competition will be required to have a competition license. Owners must be members of ASHA, in good standing, to obtain a

competition license. Applications are available from the ASHA office. No donkeys or mules allowed.

C. Competition licenses are permanent when issued to each horse and are not renewed each year. A fee will be charged for the original license, for replaced licenses and for transfers of ownership.

D. For a horse registered with a breed association, a photocopy of a horse's breed registry papers must accompany the competition license application. Non Breed Registered Horses must provide photos or drawings of full left side, full right side and a head view that include all identifying markings and brands. Attaching a copy of an E.I.A. (Coggins) laboratory test result properly executed to include age will be sufficient. A digital photo I.D. on Coggins test papers is preferred.

F. A horse's registered breed name will be used as the ASHA competition name. Owners of non-breed registered horses may select a name, provided the name does not appear in the ASHA database prior to the date of application.

G. The competition license will be returned to the recorded owner. The owner will be responsible for getting photocopies of the license to any person needing them for entry in any ASHA approved event. Competition licenses that have been lost for any reason such as: lost in the mail, misplaced, destroyed, or not received from the previous owner, can be replaced by completing the Affidavit process and submitting the appropriate fee.

H. In the case of a competition license transfer, it is the responsibility of the purchaser to obtain and submit all transfer paperwork and fees prior to the horse being shown.

I. When a horse has been gelded, such fact must be reported to the ASHA office immediately. This must be done by providing the ASHA office the horse's original competition license and a statement from the owner of record indicating the date the horse was gelded. The ASHA office will make the appropriate notation on its records and on the competition license and return the license at no charge.

J. Registration certificates can only be corrected by ASHA office. In most circumstances of correction, a new certificate will be issued with proper notation. The owner may receive free corrections within thirty (30) days from time registration is mailed from Association office by mailing certificate back to the association office accompanied by the necessary documentation for the change. Such corrections will not include a change of name from one which has been submitted by the owner.

K. To enter ASHA approved competitions, the competition license (original or photocopy) must be shown to the show secretary taking the entries.

L. At an ASHA competition, a horse that has not been issued a competition license, may complete an application with the appropriate application fee attached and show in that one competition with a (P) for pending designation. Owners must provide all documentation to the ASHA office within fourteen (14) days or the application fee will be forfeited and the application deemed void. No points will be awarded to exhibitor or horse until all requirements are met.

M. ASHA will endeavor to use the same name for a horse as are on the breed registration papers and will recognize only one ownership for a horse registered with another association. Any misrepresentation or false statement on the license application shall constitute unsportsmanlike conduct and will subject owner and/or exhibitor to disciplinary action as set forth in the ASHA Handbook.

N. ASHA expressly reserves the right to order any of, but not limited to the following: photographs, inspection, documentation of any horse currently registered with ASHA or any horse making application for registration to ASHA to ensure conformance with rules and regulations set forth in the Official Rule Book of the Association. ASHA reserves the right to deny licensing. If a horse is denied licensing, fees will be refunded.

O. ASHA, its officers, directors, members of committees, employees, representatives and agents will attempt to obtain true and complete information regarding all matters relating to ASHA activities. Except for intentional wrongdoing, neither ASHA nor its officers, directors, members of committees, employees representatives nor agents will be liable in any way, whether in damages or otherwise, for issuance of any certificate, refusal to transfer any certificate for any disciplinary procedure brought against or penalties imposed on any

member or persons or for any other activities engaged in, by or on behalf of the ASHA.

ASHA EVENTS

EV-000 GENERAL ASHA EVENTS RULES AND REGULATIONS

Effective Date and Repeal. The following Rules and Regulations shall become effective January 1 of the current year, and thereupon all rules and Regulations and parts thereof heretofore in force are hereby repealed. Rules as printed in the ASHA Official Handbook shall be used at all ASHA approved shows throughout the current year unless otherwise approved by ASHA.

EV-005 SPECIAL NOTICE TO EXHIBITORS, JUDGES AND EVENT MANAGEMENT

- A. Exhibitors, Judges and Show Management are responsible for knowledge of and compliance with all ASHA Rules, Requirements and Regulations.
- B. Participants in approved ASHA Events are responsible for showing the original or photocopies of Membership Cards and Horse Competition Licenses at each ASHA approved event.
- C. Exhibitors are responsible for completing Entry and Registration Forms legibly and accurately with information exactly as printed on membership cards and horse competition licenses.
- D. Exhibitors are to be considerate of other exhibitors, judges and show management.

EV- 010 RELEASE OF LIABILITY

A. ASHA and co-sponsoring organization, if any, will not be responsible for any accident that may occur to, or be caused by any horse participating in an ASHA approved event, or for any article of any kind or nature that may be lost or destroyed or in any way damaged. The ASHA will not be responsible for any financial arrangements not completed between event management, exhibitors, owners, or judges. However, these situations should be reported in their entirety to the ASHA for possible disciplinary action.

B. Each event should obtain blanket liability insurance to cover suits, claims or judgments for bodily injury or property damage sustained by spectators, participants, or others arising out of the use of the show grounds or operation necessary or incidental to the event.

EV – 020 ASHA EVENT APPROVAL REQUIREMENTS

ASHA Event approval is a privilege, not a right, granted or rejected at ASHA discretion on an annual basis according to continuous evaluation of the applicant, including, but not limited to competence of event management, enforcement of ASHA rules; quality of event; and service to ASHA Members.

All approved classes must be open to any ASHA member meeting eligibility requirements. **All events approved by ASHA shall have ASHA as the only mandatory membership required to participate. Other fees for participation in other organizations or special series may be offered, but not mandatory.** All events approved by the ASHA shall be named, advertised, listed and otherwise referred to as a Stock Horse Versatility Event and must state “ASHA Approved”.

The rules and requirements set forth in the ASHA Official Handbook shall be used at all approved events including any non-ASHA point classes offered at that event, unless otherwise approved by the Executive Director of the ASHA. Failure to follow the ASHA rule book in conducting events may result in future approval of events being denied and/or possible disciplinary action. The Executive Committee will decide such cases.

Approval does not carry over from year to year and must be obtained for each individual event. The ASHA reserves the right to approve only the number of events per calendar year it deems appropriate for the same organization, management or area.

Organizations or individual members wishing to stage or sponsor ASHA Regular Events (clinic & competition) or Special Events (instructional shows, awareness clinics, team tournaments, collegiate events, etc.) must obtain approval for their event from ASHA. ASHA, in turn, will publicize the event prior to and after the event and the participation and results will be available for individual members and their horses and results and points will be available for a database search of past points and awards earned by horses, members and horse-rider combinations.

EV – 025 ASHA EVENT APPLICATION REQUIREMENTS

Applicants desiring to hold an ASHA-approved event must obtain prior ASHA approval on an application form available from ASHA, if applicant desires the event to have ASHA sanction and publicity and, if show results are to be recorded by ASHA and points awarded to the horses and riders participating. In case of double judged shows or two separate shows held on consecutive days, two ASHA Event Applications must be submitted with appropriate fees. Separate ASHA Event Reports and fees are to be submitted to ASHA from each event within 14 days.

A. Application: To obtain approval, an ASHA Event Application Form must be obtained from the ASHA office and must be correctly and entirely completed. Application fees are non-refundable and must accompany the initial application. The fees are \$25 application fee for a Special Event (Team Tournaments, Exhibition Events, Awareness Clinics, Collegiate Events, One Division Events, Etc.) and \$25 for a Clinic and Competition.

B. Postmark Date: Event application form(s) must be postmarked at least ninety (90) days prior to the first date of the proposed event and must be accompanied by a non-refundable fee as per competition application. All ASHA approved event dates will be posted on the ASHA website and publication calendar of events.

C Event Date and Location Approval. Event applications are approved based upon the date of the week. AN ASHA approved event having been held the previous year is considered an established event and has priority to reserve identical days for the current year until terminated by ASHA. Priority dates are a privilege not a right, and therefore cannot be sold or transferred from one sponsoring body or management to another. In the event the previous sponsor does not obtain approval for the event date, then a regional or state association has first priority on the date. An event not approved or held the prior year is considered a new event. Additionally, an event which changes sponsoring body (the individual, organization or association financially responsible for holding the event) or the event name or changes location more than 250 miles is considered a new event without priority for days. Violations of this rule could result in disciplinary action.

D. Cancellation of Event Dates: Sponsors of events who cancel their dates must notify the ASHA IMMEDIATELY so the dates can be made available to another sponsor

E. Time and Mileage between Event Dates: Two events may not be approved on the same date if they are located within 250 miles of each other. The last sponsor of any individual show has the right to sponsor the show in the following year, provided their application is received. It is recommended that ASHA events not be held in the same 250 mile radius within two weeks of each other.

F. Time and Mileage Waiver: If all affected event managements agree to waive the time and mileage rule, then, approval may be granted.

G. Failure To Pay Services: The sponsor or sponsors of any ASHA approved event which fails to pay for any services rendered by a third party (i.e. judges fees, cattle fees, facilities or to pay premium money to exhibitors, etc.) in connection with the holding of an approved event will be denied ASHA approval for future events until all fees are paid.

H, Affiliate or Series Circuit Approval: For an affiliate or series circuit of ASHA Events to be approved, the Affiliate must complete an ASHA Circuit Application with completed ASHA Event Approvals and Fees attached for each individual ASHA Event listed on circuit application. (This circuit application will be useful for affiliates approving ASHA events for their local affiliate end-of- year points). For individual Event approval and circuit approval to be completed, the circuit application must be submitted 90 days before the first event scheduled on the circuit.

I. ASHA Event Approval Notification: Event officials will be notified by ASHA if their event is approved or what factor(s) need to be rectified so that the event may be approved. ASHA will provide management and secretarial guidelines and support as well as official show reporting requirements to the event sponsors upon Event approval.

EV - 030 MINIMUM REQUIREMENTS FOR ASHA EVENTS

A. An ASHA Event must be open to all ASHA members in good standing. Participants must hold a current ASHA membership card to participate. Participants and Exhibitors may purchase ASHA Memberships and Horse Competition Licenses at ASHA approved events.

These new/renewal membership forms and/or horse competition licenses purchased at an event must be submitted to the ASHA office with the reports, results and fees for the memberships and licenses and for the event.

B. All approved ASHA Competitions are open ONLY TO horses having a competition license certification with ASHA. Horses ridden in clinics do not have to have an ASHA competition license.

C. All riders of horses riding and/or showing in Association approved competitions must be members in good standing. When entering Association approved classes, entry forms must identify horse and rider with the correct and current membership number.

D. Sanctioned events require compliance with all ASHA Association rules and guidelines, fees, and documentation.

E. A regular ASHA Event is considered to be a clinic and a competition. The recommended schedule is to have a clinic one day and a competition the following day or day(s).

1) ASHA Clinics - It is recommended that clinics offer sessions in all four ASHA versatility events – pleasure, trail, reining and working cow horse and be affordable to participants. Participation in clinic reports must be compiled as required by ASHA and reported within 14 days to the ASHA office with all necessary attachments and fees

2) ASHA Competitions – Competitions must offer the four ASHA versatility classes of Pleasure, Reining, Trail and Working Cow Horse conducted and judged according to the rules of ASHA. Points must be awarded for each class as well as all-around placing in each Division that is offered according to ASHA rules and point systems. ASHA score sheets must be used by judges, compiled as required by competition secretaries and, reported within 14 days to the ASHA office with all necessary attachments and fees.

a) ASHA competitions may offer five divisions that are based entirely on the rider, regardless of the horse they are riding. These divisions are Open, Non-Pro, Limited Non Pro, Novice and Youth.

b) ASHA competitions may also include a green horse division based entirely on the horse. This green horse may be shown by any exhibitor regardless of division or classification.

c) A rider may show more than one horse in a division, but high point awards shall be based on a one horse/one rider team showing in all four classes.

d) No horse may be shown in the same class more than once.

e) Competitions must offer a minimum of two divisions - an Open and a Novice Division. Competitions are encouraged to offer as many of the six divisions as meet local needs.

f) Show management must inspect the membership card or a photocopy of the card at any competition entered. ASHA membership applications and ASHA Collegiate membership applications shall be provided by show management at all ASHA competitions. The membership applications and the appropriate fees must be submitted with the competition results report.

g) Show management must inspect the Horse Competition License or photocopy of each horse being exhibited in an ASHA competition. ASHA Horse Competition License applications shall be provided by show management at all ASHA competitions. The horse competition license applications and the appropriate fees must be submitted with the competition results report.

h) Health requirements should be outlined on flyers and event announcements and enforced by the event management

EV-037 ASHA DIVISIONS AND ELIGIBILITY

A. Open Division Eligibility – Every person competing in an open division must possess a current ASHA Membership card issued by ASHA. The Open Division is open to any professional or non-professional member, in good standing, with any horse regardless of past winnings. In addition to the normal entry fee, this division may collect and offer jackpot fees which will be paid back to winners according to the payout schedule in the ASHA Rule Book. These jackpot fees may range from a minimum of \$10 to a maximum of \$20 per class except for special events or championships.

B. Non Pro Division Eligibility – Every person competing in a non pro division, which includes limited non pro and novice, must possess a current ASHA Non Pro Membership card issued by ASHA. The description of Non Pro Eligibility is as follows:

1. Has not received payment, directly or indirectly for riding, training, assisting in training, showing horse(s) at any time during the past 5 years
2. Has not received payment directly or indirectly for instructing another person or conducting a seminar in riding, training, driving or showing a horse any time during the past five years
3. Has not had any expenses (including lodging, transportation, mileage, etc.) paid by someone else other than family members

EXCEPTIONS for 2 and 3 above

A Non-Pro who otherwise qualifies, under these rules may conduct clinics provided the only remuneration they receive is reasonable expenses. If questions are raised about non-pro eligibility, contestant must be able to document that any remuneration was for expenses only.

Collegiate Members, - Students, while enrolled in an equine program as part of an educational curriculum is exempt from items 2 and 3 above.

(Please note that these EXCEPTIONS are for ASHA only and individuals should check with other association non-pro rules if they are concerned.)

4. Premium money won is not considered remuneration.
5. A non pro may show in the Open Division without losing their Non Pro Eligibility as long as requirements for a Non Pro are still met.

C. Limited Non Pro Division Eligibility – Exhibitors who qualify as a Non Pro Rider may choose to show in this division because of class routine or other personal choice. Exhibitors may also show in the Open or Non-Pro divisions without losing their eligibility in the Limited Non Pro division. There will be no jackpot in this division. Riders in this division will work a modified version of the working cow horse class which will not involve turns down the fence, circling or roping (see ASHA LTD Non Pro and Green Horse Working Cow Horse rules for specifics on rules for this division.)

D. Novice Division Eligibility and Restrictions–The Novice Division is reserved for individuals with limited riding and showing experience who wish to learn more about showing in ASHA at a beginners pace. Everyone new to ASHA competition doesn't necessary need to start in the Novice division. Their skill may be better suited for one of the other divisions.

Individuals competing in a novice division must possess a current ASHA Non Pro Membership card with eligibility for Novice division noted on the card. There will be no jackpot in this division. Eligibility for the Novice division is as follows:

1. Adheres to all non pro eligibility requirements
2. Has never won a High-Point or Reserve High-Point Championship in any division at any ASHA show **or similar association**
3. Has never won an End-of –Year All Around High Point Champion or Reserve All around High Point Champion in any division in ASHA or **similar association**.
4. **Has had no showing experience in cow horse, cutting or any other cattle-working events and has had less than four years showing experience in other classes prior to participating in ASHA.**
5. If a member loses their novice eligibility through competition, they may finish that year as a novice. In the future, the member is eligible only for Limited Non-Pro, Non-Pro, Open or Green Horse Divisions.
6. Riders in this division will work Novice and Youth Reining Patterns and a Novice and Youth Working Cow Horse Pattern. The cow horse pattern is a shortened version of cow work which will not involve turns down the fence, circling or roping. (See ASHA Novice and Youth Reining and ASHA Novice and Youth Working Cow Horse rules for specifics on rules for this division.) Stallions are prohibited in this division.

E. Youth Division Eligibility and Restrictions - Exhibitors in the youth division must be youth, aged 8 through 18 as of January 1 of the current year. Youth competing in a youth division must possess a current ASHA Youth Membership card issued by ASHA. Riders

in this division will work a Novice and Youth Reining Pattern and a Novice and Youth Working Cow Horse Pattern. The cow horse pattern is a shortened version of cow work which will not involve turns down the fence, circling or roping. (See ASHA Novice and Youth Reining and Working Cow Horse rules for specifics on rules for this division.) A youth may not show in both the Youth and Novice Divisions at the same show. Stallions are prohibited in this division.

F. Green Horse Division Eligibility and Restrictions – Horses competing in the green horse division must possess an ASHA Horse Competition License. Any rider possessing a current ASHA membership may show a horse in this division. There will be no jackpot in this division. Horses in this division will show in the same patterns as the Open and Non Pro with the exception of the working cow horse class which will be the Modified Working Cow Horse pattern. (See ASHA LTD Non Pro and Green Horse Working Cow Horse rules for specifics on rules for this division.)

1. A horse is eligible to be shown in this division if the following criteria are met.
2. Be five years of age and younger as of January 1 of current year.
3. Has never won a Champion or Reserve Champion All-Around in any ASHA approved division.
4. If a horse loses their green horse eligibility through competition, they may finish that year as a green horse. In the future, that horse is eligible only for other divisions.
5. A green horse may be shown by a rider from any division.

G. Division Eligibility Exceptions The ASHA shall have a classification committee from the ASHA Board of Directors. A member may petition, in writing, the ASHA Classification committee for a change in division eligibility due to extenuating circumstances. The written petition will be reviewed and the member notified of the ruling. In addition, the committee may reclassify a member for a division.

H. Eligibility Violations Non Pro, Novice, Youth, and Green Horse Eligibility may be revoked at any time for violations of any ASHA rule or regulation. A person revoked from these special division statuses must relinquish their membership card and return it to the ASHA upon notice.

EV-039 HORSE ELIBIGILITY AND LICENSING

A. All horses in an ASHA approved competition must show their ASHA Competition License Certificate or photocopy to participate in an ASHA competition. ASHA Competition Licenses may be purchased at an ASHA event and horses may show in a show without an approved competition license, but with a PENDING license provided an ASHA Competition License Application is completed with

- a. A copy of Horse breed registration papers attached for registered horses or,
- b. A copy of veterinarian statement verifying age and description of horse with appropriate markings and brands for unregistered horses attached. (An E.I.A. (Coggins) laboratory test results properly executed to include age will be sufficient for nonregistered horses.) A digital photo I.D. on Coggins test papers is preferred.
- c. and payment of licensing fees.
- d. Without identification papers listed above, an additional \$10 will be charged.

B. No horse may be shown in the green horse division without an ASHA competition license as proof of age and eligibility for green horse division.

C. A horse may be shown in any division by eligible riders Excepting only horses that meet green horse division eligibility may be shown in that division.

D. A horse may not be shown in any class more than once.

EV-042 CLASSIFICATION AND TYPES OF SHOWS

A. Competition Classifications - Competitions shall be classified according to the number of entries in approved classes and guidelines will be provided to help show management conduct shows with the corresponding expected number of entries and report their competition accordingly.

- Class A Competitions 130 - 200 or more horse/rider combinations
- Class B Competitions 75 – 130 horse/rider combinations
- Class C Competitions 30 – 75 horse/rider combinations
- Class D Competitions 30 or less horse/rider combinations

B. Single Judged Shows: A single judged show is limited to one judge in one arena or area at any given time and held on one or more days. Scores from one judge in each event are tabulated, places broken by pre-determined judge's tie-breakers, and exhibitors ranked and pointed. Points from each class are added to determine the all-around division winners.

C. Doubled Judged Shows – Double judged shows have two judges in one arena or area at one time, judging independently of each other.

For two independent show results: each independent judge's score sheets in each class will be turned into show secretary and tabulated separately for pointed rankings, which will be determined according to the number of entries in a class. Scores from each judge in a class are tabulated, places broken by the judge's pre-determined tie-breakers, and exhibitors ranked and pointed under each judge. Each judge's scores, class placings and points will be posted separately. Judges for Show A and Show B for each class should be determined before the show and points kept for two complete shows – keeping all of Show A Judges scores together and all of Show B Judges scores together can result in two different and complete shows results being determined.

For one combined show result: When using two judges to determine one set of winners, the classes will first be placed under each judge and complete class scores showing class placing and points awarded for placings will be posted. One judge shall be designated as the tie breaker judge before judging begins. The final class placings and winners will have the placing or ranking points from each judge added together with the tie breaker judge's placing points breaking ties and class winners being named. Exhibitors competing in all four classes shall have their points from the final class placing points which were determined by both judges entered into one All-Around tabulation. All around winners will not be selected for each judge, but all around winners will be selected on the basis of the one set of points from the final class ranking being entered into one All-Around tabulation. Pay out monies will be paid based on the final placings based on combined judge's scores. Ties will be broken first by the working cow horse class, then by reining, trail and pleasure.

EV -050 EVENT MANAGERS FOR ASHA CLINICS AND COMPETITIONS AS WELL AS SPECIAL EVENTS

A. Eligibility Any reputable person who can furnish proof that he/she is capable through ability or experience may act in the capacity of the event manager. The Event Manager and Secretary should be a current member of ASHA.

B. Person in Charge – The event manager shall be the person in charge of the ASHA event. MANDATORY attendance OF THE SHOW MANAGER ON THE EVENT GROUNDS IS REQUIRED WHILE HE/SHE IS IN CHARGE

C. Announcement Flyers, Entry Forms, and Show Schedules – The Event Manager shall have the jurisdiction over preparing and mailing all items related to the event. The event manager shall provide announcement flyers, schedules, entry forms, etc. to the ASHA Office at least 60 days prior to the event for publicity purposes. The manager shall enforce the arrival and departure times as advertised.

D. Responsibilities - The event manager shall at all times extend every effort to satisfy the comfort of the horses, the exhibitors, the spectators and the officials. The manager shall be held responsible for maintenance of clean and orderly condition throughout the event. The manager is responsible to see that ASHA Event Reports, Fees and competition results are submitted to the Association within fourteen (14) days of the last date of the event.

E. Authority - The event manager shall have the authority to enforce all rules and requirements referring to the event. The manager may excuse any horse or exhibitor from the event for the safety of other horses, exhibitors or spectators or remove an exhibitor for unsportsmanlike conduct.

F. Retain Copies of Judges Sheets–The show management shall retain copies of original signed judges score sheets, copy of show results and entry forms for at least one year.

EV 055 SHOW SECRETARY

A. Eligibility- Any reputable person may act in the capacity of show secretary who can furnish proof that he or she is capable through ability and experience and is familiar with ASHA rules and procedures. The show secretary may not hold the position of show manager or ring steward at a show at which he/she serves as show secretary. The show secretary shall be the primary person responsible for verifying exhibitor and horse/s eligibility and correctness of clinic and show reports and results, thus requiring MANDATORY attendance of the show secretary on the event grounds throughout the duration of his/her responsibilities at the event.

B. Responsibility - The responsibility of the show secretary shall be to

1. Serve as primary contact for show results by recording both entries and show results and maintaining these records for at least one year
2. Submitting ASHA Event Reports and monies along with competition results in hard copy to the Association within fourteen (14) days of the last date of the event. Competition results in electronic format should be submitted to the Association as soon as possible after the event.

EV – 060 COMPETITION RESULTS

A. Submission of Competition Results –

The submission of the original, correct and ACCURATE competition results to ASHA must be postmarked and sent by electronic (e-mail) within 14 days. Any competition results including all official judges' sheets signed by judges, any ASHA fees, membership or horse registrations joined at competition not received in the ASHA office within 14 days of the last Event may be subject to a \$50.00 late fee.

Each class result sheet must list the actual number of horses that competed in the class including the name of the horse on the ASHA competition license, the ASHA number of the horse, the exhibitor's name and the exhibitor's ASHA number. Other information as requested on each class sheet must be completed and the original score sheet must be signed by the judge. All forms and electronic score sheets will be supplied to a show secretary when an ASHA competition is officially approved.

B. Competition Assessment Fees –

Competition management must collect a \$5 bookkeeping fee per horse/rider entry per show AND FORWARD TO ASHA OFFICE WITH THE COMPETITION RESULTS IN ORDER FOR COMPETITION RESULTS TO BE PROCESSED. These fees help to defray the costs of record keeping and ASHA Certificates and/or awards

C. Competition results must be submitted in the format specified by the ASHA accompanied by the original, signed, final judges' score sheets.

D. Retaining Records – At the close of the competition, the event management shall retain copies or duplicates of the judges' original signed, final placing score sheets, a copy of competition results as received from ASHA and competition entry forms for one (1) year from date of show.

E. Competition Result Mailing or Cancellation Deadline – Failure to mail the completed show result forms or notification of cancellation to the Association within fourteen days of the last scheduled event date may result in future approval being denied. Competitions which are more than thirty days delinquent in filing their results may be fined.

F. Publication and Correctness of Competition Results – Competition results of ASHA approved events will be listed on the Official Association Website. A period of six months from the date of the competition will be allowed for a correction of show results. After that date, no request for competition result correction will be considered. It is the responsibility of the exhibitor to notify ASHA of any possible errors in competition results.

Discrepancies – Discrepancies between ASHA approved events and programs, divisions and classes actually offered and conducted at the event shall be presented to the Executive Committee for judgment when properly submitted by participants or show management.

EV- 090 POINTS

Points shall be awarded to qualifying horses entered and exhibited in ASHA approved competitions and events according to ASHA rules. Each class must be placed through the

total horses actually judged in that class and points awarded to each horse that placed. Points will be awarded with the horse placing first receiving one point for every horse they placed above plus 1. Example: If 28 horses are in a class, the first place horse gets 28 points, the second place horse gets 27, etc. If a horse is disqualified (DQ) in a class, he receives no points and is listed at the bottom of the class sheet with a DQ noted. Disqualified horses count as entries in a class with a DQ or 0 noted in the points received and the horses placing above them receive points for the total number of horses shown in the class including the disqualified horses.

EV-100 ASHA SCORING SYSTEM

A. The ASHA Scoring System is designed to be positive and straight forward - always encouraging growth and improvement. The scoring system is a positive one rather than a negative one which leads to many disqualifications. These rules give a horse credit for what they accomplish rather than a disqualification with no score. **Scores for each maneuver are scored 0-10. However, 0 is used only if an exhibitor leaves out part of a class or chooses to not attempt a maneuver, a portion of the score for this maneuver may be 0. All maneuvers of a class that are attempted should receive at least a 1.**

B. No horse shall be disqualified except for illegal equipment, obvious lameness, or inhumane treatment or misconduct from the rider.

C. In the case of a fall by a horse or rider, the run shall end when the rider or horse falls to the ground. A horse is considered fallen when all four feet are pointing in the same direction. A horse will be given credit for what he has done prior to the fall.

D. In the case of equipment failure that delays competition or becomes unsafe, the run is stopped and the horse is given credit prior to that point.

E. Using two hands on a curb bit or using more than one finger between split reins or any finger between romal reins will result in a two point run content deduction each time there is a violation. Continuous use of two hands on reins with curb bit is a major fault and should be reflected in the maneuver score.

F. Specific deductions are listed with each class.

G. POINT SYSTEM: The judge must place each class in its entirety. The judge should avoid ties, one-half points are permissible. Specific maneuvers will be designated by the judge to be tie breakers in a class. The tie breaker maneuvers will be made prior to the start of the class and so noted on score sheets for show secretary to use in breaking ties in the class. Every horse in the class is awarded one point for each horse they beat, plus one point. (Examples: In a ten horse class, the first place horse gets ten points and the tenth place horse gets one point. In a five horse class the winner gets five points and the last place horse gets one point.)

Disqualified horses will count as entries in the class, but will not receive points (A class with a disqualified horse: In a twenty one horse class where one horse is disqualified, the first place horse gets twenty one points, the twentieth place horse gets two points and the disqualified horse gets 0 points. The last point is not given because the disqualified horse gets no points.) This system will be used for any size class and may include more than one disqualification.

H. HIGH POINT TIES: High Point ties for each competition and year end awards will be broken by awarding the high point award to the horse/rider with the highest placing in the working cow horse class. If this doesn't break the tie, the other classes will be used in the following order, reining, trail and pleasure.

EV-110 JUDGES

Judges should have equine expertise and personal character to merit the honor of being asked to judge. Judges must be knowledgeable horsemen. Judges must read all contest rules as well as the procedures for judging the events and agree to use these procedures and score exhibitors according to the class rules.

Judges in all ASHA Events are prohibited from judging family members.

EV-120 ASHA JUDGING PROCEDURES

A. ASHA Score sheets shall be used to judge all classes. Specific maneuvers will be selected by judges prior to the class as tie-breaking maneuvers. These maneuvers will be ranked as first tie breaker, second, third, fourth, fifth, etc.

B. During the class, a scribe shall assist each judge by recording the score after each of the maneuvers on the appropriate class score sheet. Judges shall sign their score sheets and the score sheets will be turned in to the show secretary.

C. Show secretaries shall total individual scores, using the judge's tie breakers in the order listed, to place the class on points earned. They will check back with the judge if there are any questions.

D. All exhibitors will be ranked according to scores, placed from highest to lowest scores, and given class points according to their placing.

E. Class score sheets shall be posted as soon as possible after each class to allow riders to evaluate their performance.

F. Exhibitors competing in all four classes shall have their class placing points entered into the All-Around tabulation. Points from each class shall be added together for the overall score for the four events. Ties for the all-around winner are broken first using the highest score in the working cow horse class, second using the reining class, and then the trail and pleasure classes.

G. When using two judges to determine one set of winners, the classes will first be placed under each judge and class placing points awarded and posted. One judge shall be designated as the tie breaker judge before judging begins. The final class placings and winners will have the placing or ranking points from each judge added together with the tie breaker judge's placing points breaking ties. Exhibitors competing in all four classes shall have the final class placing points which were determined by both judges entered into the All-Around tabulation. Pay outs will be made on the final class placings and all around placings.

EV-130 SCRIBES

Scribes are provided to assist the judge with the record keeping aspect of judging. Scribes should not double as a ring steward, but be available at all times to record scores given by the judge. A scribe's integrity must be above reproach and they must be willing to be attentive and accurate at all times. They should not attempt, in any way, to influence or change a judge's score, but always be available to assist the judge.

EV-140 ASHA COMPETITION EQUIPMENT AND ATTIRE

A. Equipment: Horses shall be shown in a stock saddle. Silver equipment will not count over good clean, working equipment. Horses, of all ages, may be shown in a snaffle, bosal, or curb bit. When a bit is used, the mouthpiece must be at least 5/16" and not more than 3/4" in diameter measured one inch from cheek and must be smooth. Nothing may protrude below the mouthpiece such as extensions or pronas. **A standard western curb bit must not be longer than 8 1/2 inches measured on the outside length from the top bridle attachment to the rein attachment. The port must not be higher than 3 1/2 inches with rollers and covers acceptable. Broken mouthpieces, halfbreeds and spades are standard.** Split reins shall be used with all bits except that a romal is acceptable with a curb bit. Closed reins are not allowed except as standard romal reins **or standard mecate reins which include a tie rope with snaffle bit or bosal.** Curb straps are required for curb bits and the curb chains or straps must be at least 1/2 inch in width and must lie flat against the horse's chin. No wire curbs are permitted, regardless of the amount of padding or tape. Absolutely no iron will be permitted under the jaws.

B. Prohibited equipment includes tie downs, cavessons, gag bits, mechanical hackamores and running martingales. A judge may prohibit the use of any equipment deemed to be inhumane.

C. ATTIRE: Riders shall wear protective headgear or western hats, long-sleeved shirts and western boots. *Western boots shall include typical cowboy boots and lace-up ropers. All other footwear is prohibited.* The use of spurs and chaps shall be optional. Clothing should be neat and clean.

EV-150 ASHA TITLES AND AWARDS

Eligibility: ASHA shall issue awards on an annual or life-time basis as described within this section with provisions that the rider of the horse eligible for such awards is a current member in good standing. ASHA awards will only be issued to rider(s) of horses selected that

have membership in the current year or year of notification should notification be given in a year following the year of earning an award or title as in the case of MERIT awards.

A. ASHA Regional Honor Roll Awards

The Association will provide a Regional Honor Roll Versatility award annually based upon the highest number of points earned by an individual horse/rider combination in the all-around in each division at ASHA approved competitions during that year's (Jan. 1 – Dec. 31) competitions. The award is based on total cumulative points (with a minimum of 8 points). In addition, ASHA will provide a Regional Honor Roll award annually based upon the highest number of points earned by an individual horse/rider combination in each of the versatility classes in each division. Regional points are counted from shows held within the region in which the show was located. The Top ten High Point of each event including the all-around in each division will be published on the Associations web-site and will be recognized in each of the events

B. ASHA Merit Award Program

ASHA offers a Merit Awards Program to recognize outstanding versatile western stock horses that have proven to be consistent over a period of time.

1. A horse/rider team is automatically awarded ASHA Merit Points by competing in either the Open or Non-Pro Divisions of approved American Stock Horse Association competitions.

2. Consistent with other ASHA policies, the Merit award is a joint award for a one horse/one rider combination earned in either the Non-Pro or Open Division in an approved American Stock Horse Association Show. Merit Points may only be awarded in one division at any one show.

3. ASHA Merit Points shall be awarded to a one horse/one rider team showing in all four classes and based on the number of entries in the All-Around or High Point Division up to a maximum of 10 points. (Example: horses may receive a maximum of 10 ASHA Merit points for being the high-point horse, 9 points for reserve, and 8 points for third, down to 1 Merit point for placing 10th high overall. If only 8 horses are entered in the All-Around – the high point horse will receive 8 points, down to 1 Merit point for placing 8th high overall.)

4. A horse may receive points with more than one rider, but the points cannot be added together for more than one rider or transferred to another rider. Horses that change riders must start over in accumulating Team Merit points for the Superior or Supreme Awards. Ownership may change, but the rider must remain constant.

5. Superior STOCK HORSE VERSATILITY Award –100 ASHA MERIT POINTS.

This award may be awarded to a horse/rider team that has earned at least 100 ASHA MERIT POINTS at approved ASHA Shows in the All-Around rankings of either the Open or Non-Pro division. Points may be combined from the two divisions as long as they were acquired at different shows. This designation shall be noted in the records of the association and certificates presented to both the rider and owner, if different.

6. Supreme STOCK HORSE VERSAILITY Award – 200 ASHA Merit Points. This award may be awarded to a horse/rider team which has earned at least 200 ASHA Merit Points at approved ASHA shows in the All-Around rankings of either the Open or Non-Pro Division. Points may be combined from the two divisions as long as they were acquired at different shows. This designation will be noted in the records of the association and certificates presented to both the rider and owner, if different.

EV-190 ASHA Entry Fees and Payback Schedule

It is recommended that novice entry fees be kept as low as possible. Non-Pro, Limited Non Pro, Novice, Youth and Green Horse entries will basically compete for points and class prizes.

1. Open classes will be charged the same entry fee as other classes, but may have an additional jackpot fee. It is recommended that the jackpot fee in each class be a minimum of \$10 and a maximum of \$20 that will be jackpotted and paid back to winners with the exception of special events. Fees should be divided into entry fees and jackpot fees. Half of jackpot fees will be for the class entered and half of the fees will go to the All-Around jackpot.

2. Class paybacks: Half of the jackpot will be for the class entered. Open class entries are competing for class points, plus a payback ($\frac{1}{2}$ of the jackpot monies collected for that class) according to the following schedule.

3. All-Around paybacks: Exhibitors in all four classes will be eligible for the All-around paybacks – ($\frac{1}{2}$ of all open entries jackpot money). The All-Around paybacks in the Open Division will pay only to exhibitors showing in all four classes. The All-Around paybacks will be figured on the total number of entries in the Open Division, divided by four (4) to ascertain the average class size on which to base the all-around paybacks. Using the average class size, the number of paybacks to exhibitors showing in all four classes will be paid according to the following schedule.

(Example: 52 total entries in open division divided by four will equal an average class size of 13 exhibitors and paybacks will go to five exhibitors showing in all four classes. (Example: 72 total entries in open division divided by four will equal an average class size of 18 exhibitors and paybacks will go to six exhibitors showing in all four classes.). (Example: 15 entries in open division, but only three exhibitors showing in all four classes – the all-around jackpot money will be paid to TWO PLACES according to the three pay outs in ASHA Pay Out Schedule.)

Number of Horses Shown

| # Places | Number of Horses Shown | | | | | | | | | | | | | | | | | | |
|----------|------------------------|-----|-----|-----|-------|-------|-------|-------|-------|-------|-------|-------|-------|-------|-------|-------|-------|-------|-------|
| | 1-2 | 3-4 | 5-6 | 7-9 | 10-15 | 16-20 | 21-25 | 26-30 | 31-35 | 36-40 | 41-45 | 46-50 | 51-55 | 55-60 | 61-65 | 66-70 | 71-75 | 76-80 | 80+ |
| 1 | 100% | 2 | 3 | 4 | 5 | 6 | 7 | 8 | 9 | 10 | 11 | 12 | 13 | 14 | 15 | 16 | 17 | 18 | 19 |
| 2 | 60% | 40% | 50% | 40% | 30% | 30% | 28% | 25% | 23% | 20% | 20% | 20% | 20% | 20% | 20% | 20% | 19.5% | 19% | 19% |
| 3 | | | 30% | 30% | 25% | 24% | 22% | 20% | 18% | 16% | 16% | 16% | 16% | 15% | 15% | 15% | 15% | 15% | 14% |
| 4 | | | 20% | 20% | 20% | 18% | 17% | 15% | 15% | 14% | 13% | 13% | 12.5% | 12.5% | 12.5% | 12.5% | 12% | 12% | 11.5% |
| 5 | | | | 10% | 15% | 12% | 12% | 11% | 11% | 11% | 11% | 11% | 10% | 10% | 10% | 10% | 10% | 10% | 10% |
| 6 | | | | | 10% | 9% | 9% | 10% | 9% | 9% | 9% | 8% | 8% | 8% | 8% | 7.5% | 7.5% | 7.5% | 7.5% |
| 7 | | | | | 7% | 7% | 7% | 8% | 8% | 8% | 7% | 7% | 7% | 6.5% | 6% | 6% | 6% | 6% | 6% |
| 8 | | | | | | | 5% | 6% | 7% | 7% | 7% | 6% | 6% | 5.5% | 5% | 5% | 5% | 5% | 5% |
| 9 | | | | | | | | 4% | 5% | 6% | 5% | 5% | 5% | 5% | 4.5% | 4% | 4% | 4% | 4% |
| 10 | | | | | | | | | 4% | 5% | 5% | 4% | 4% | 4% | 4% | 3.5% | 3.5% | 3% | 3% |
| 11 | | | | | | | | | | 4% | 4% | 4% | 3.5% | 3.5% | 3.5% | 3.5% | 3.5% | 3% | 3% |
| 12 | | | | | | | | | | | 3% | 3% | 3% | 3% | 3% | 3% | 2.5% | 2.5% | 2.5% |
| 13 | | | | | | | | | | | | 3% | 3% | 3% | 2.55 | 2.55 | 2.5% | 2.55 | 2.5% |
| 14 | | | | | | | | | | | | | 2% | 2% | 2% | 2% | 2% | 2% | 2% |
| 15 | | | | | | | | | | | | | | 2% | 2% | 2% | 2% | 2% | 2% |
| 16 | | | | | | | | | | | | | | | | 1.5% | 1.5% | 1.5% | 1.5% |
| 17 | | | | | | | | | | | | | | | | | 1.5% | 1.5% | 1.5% |
| 18 | | | | | | | | | | | | | | | | | | 1.5% | 1.5% |
| 19 | | | | | | | | | | | | | | | | | | | 1.5% |

EV-200 American Stock Horse Association Classes

Following is a list of the four classes, designed to measure the versatility of a western stock horse, to be offered at each American Stock Horse Association competition with descriptions and guidelines for judging: Each class must always be a standalone class **and run independently of any other class**. Schedules should be established to allow time between classes for exhibitors to prepare their horse for the next class.

EV-210 ASHA Stock Horse Pleasure Class

- This class serves to measure the ability of the horse to be functional and a pleasure to ride while being used as a means of conveyance from one task to another. This horse should be well-broke, relaxed, quiet, soft and cadenced at all gaits.

- The horse should be ridden on a relatively loose rein with light contact and without requiring undue restraint. Excessively long floppy reins will not be given extra credit. The horse should be responsive to the rider and make all required transitions smoothly, timely and correctly. The horse should be soft in the bridle and yield to contact.

- **Horses shall be shown individually at the walk, trot and lope in both directions. The walk, trot and lope will be extended in one direction only.**

- **The class should be conducted inside of an arena. An arena provides good footing for stops in the pattern.** The pattern may be started either to the right or left direction.

- The order of gaits shall be: 1) Extended Walk 2) Trot 3) Extended Trot 4) Lope 5) Stop and Reverse 6) Ordinary Walk 7) Lope 8) Extended Lope 9) Trot 10) Stop and Back

- The extended trot may be ridden with the rider either posting or standing in the stirrups to the front of the saddle. Holding the saddle horn is permissible, at this gait, as might be done in open terrain. When transitioning from the extended trot to the lope, it is permissible to take the horse back a bit (collecting) before loping. The reverse may be executed in either direction.

- Individual Markers shall be setup to designate gait changes. When establishing or setting up markers, the following distances are recommended. These distances will make for a more fluid class to be exhibited and facilitate ease in judging. In smaller arenas, it may be necessary to adjust the course to get distances similar to those recommended.

- 1) Extended Walk - 75 feet
- 2) Trot - 120 feet
- 3) Extended Trot - 240 feet
- 4) Lope - 150 feet
- 5) Stop and Reverse
- 6) Ordinary Walk - 30 feet
- 7) Lope - 150 feet
- 8) Extended Lope - 200 feet
- 9) Trot - 90 feet
- 10) Stop and Back

- **The judge shall walk the pleasure class and approve the markers for distances. The judge shall judge the pleasure class from the center of the arena except in extreme circumstances.**

A. Description of Ideal Pleasure Gaits

The ideal pleasure horse will have a level head carriage at each gait – neither too high nor too low.

1. Extended Walk – A stock horse pleasure walk should be straight, square flat footed, relaxed and should move out freely with horse looking ahead, The extended walk should show more length of stride than the ordinary walk.

2. Trot – This gait should be a square two-beat diagonal trot. The trot should be steady, soft and slow enough for riding long distances. Trots which are rough and hard to sit should be penalized. Excessively slow and uncadenced trots should also be penalized.

3. Extended Trot – The extended trot should show an evident lengthening of stride from the regular trot with the same cadence that will cause an increase in speed. This trot should be level, flat and steady with the appearance that the horse would hold this gait for an extended distance.

4. Lope – This gait should be a three beat gait that is cadenced, straight and steady and is comfortable to ride over long distances

5. Stop (from both lope and trot) – The horse should be in the correct stopping position – both hocks engaged and stopping on the hindquarters.

6. Reverse – A horse should turn briskly and flat with front feet on the ground and holding an inside rear pivot foot.

7. Ordinary Walk – A stock horse pleasure walk should be straight, square, flat footed, relaxed and should move out freely with no anticipation to move to the next gait.

8. Extended Lope – This gait should be an obvious lengthening of stride from the previous lope, be at the same cadence and cause an increase in speed. The gait needs to be steady, quiet, and holding the increased speed while being under control.

• **Part of the evaluation of this class is on smoothness of transitions.** There is no advantage to making these transitions with cues that are imperceptible to a judge. Judges expect to see horses that been trained to respond to cues. To see these cues applied discretely and the horse responding correctly could be a credit earning situation.

All transitions should be smooth without undue fuss from the horse. Please note that the rules allow for a horse to be taken back (collected) a bit from the extended trot as the horse moves into the lope. The transition from the extended lope down to the trot is very difficult to achieve, however, a good stock horse will have to make this transition several times during a day's work. This transition is down to the normal or sitting trot not the extended trot. Therefore, an extra cue to achieve this gait is expected. Horses that complete this total transition within three strides calmly and obediently should be rewarded. Horses that bring the hocks together to go into a stopping position should be penalized according to the magnitude of the error.

B Scoring Stock Horse Pleasure

Each gait, including transitions toward that gait, will be scored from 1-10. There will be 5 scores in each direction for a total of 10 scores and a maximum of 100 points for each horse's work.

The scoring guide for each maneuver, including transitions, is as follows:

- 1-4 Points – Major faults such as wrong lead, broken gait, lack of control, very poor quality of gait, failure to perform requested gait.
- 5-7 Points – Average quality of movement of gaits and transitions with minor or no faults
- 8-10 Points –High quality mover that is functionally correct in gaits and transitions. Well-mannered and responsive.

EV 220 ASHA Stock Horse Trail Class

A horse is ridden through a pattern of obstacles which should nearly approximate those found during the course of everyday work. The horse is judged on the cleanliness, neatness and promptness with which the obstacles are negotiated, ability to negotiate obstacles correctly and attitude and mannerisms exhibited by the horse while negotiating the course. Emphasis on judging should be on identifying the well-broke, responsive, well-mannered horse which can correctly negotiate the course. Management, when setting courses, should keep in mind that the idea is not to trap a horse, or eliminate it by making an obstacle too difficult. All courses and obstacles are to be constructed with safety in mind so as to eliminate any accidents.

A.COURSE REQUIREMENTS, DEVELOPMENT & POSTING

1.The trail class should be conducted on natural terrain outside of an arena if at all possible. An outside natural terrain provides a more realistic setting in which a horse may negotiate a pattern of obstacles. This tests the horse's ability to cope with many situations encountered in everyday riding. In case of inclement weather or extenuating circumstances, the trail class may be held in an arena after another class has been completed or before another class has been initiated.

2.Course will include no less than six and no more than nine obstacles.

It is mandatory that the horse be asked to walk, trot and lope during the course. The walk can be part of obstacle score and scored with approaching obstacle. The trot should be at

least 35 ft and scored with approaching obstacle. The lope should be at least 50 ft and scored with approaching obstacle and be lead specific.

3. Care must be exercised to avoid setting up of any obstacles that may be hazardous to the horse or rider.

4. NO EXTRA VERBAL INSTRUCTIONS MAY BE GIVEN TO EXHIBITORS BY MANAGEMENT OR JUDGE THAT IS NOT WRITTEN IN COURSE DESCRIPTION.

Since exhibitors in ASHA shows may be riding up and completing their trail course individually, there will not be a time that all exhibitors can hear or know about extra instructions or credits that the judge might want to use. Any instructions to the exhibitors must be written on the trail pattern and posted before the beginning of the trail competition.

5. Show committees have the option of setting up the trail course to best fit their conditions. Each single performance event can be time-consuming, so it is imperative that time restrictions are placed on this class. The show committee, either through a pilot run or estimation, shall select a course that has a continuous positive flow that can be negotiated in a reasonable amount of time. (4 minutes or less).

6. Judges must walk the course and have the right and duty to alter the course if it is not in keeping with the intent of the ASHA trail class. Judges may remove or change any obstacle they deem unsafe, non-negotiable, or unnecessarily difficult. If any time a trail obstacle becomes unsafe during a class, it shall be repaired or removed from the course. If it cannot be repaired and some horses have completed the course, the score for that obstacle shall be deducted from all previous works for that class.

7. **The actual trail course cannot be made available to exhibitors or posted prior to the day of competition, but must be posted at least one hour prior to competition.**

Printed handouts for contestants is helpful and encouraged

8. The course may be walked on foot by the exhibitor or, in the case of outdoor courses, be observed from the outside of the course on horseback, but no horse/rider exhibitors are allowed on the actual course after it has been set until their trail run begins.

B. TRAIL CLASS OBSTACLE REQUIREMENTS:

1. Course must be designed using the mandatory obstacles and maneuvers plus optional obstacles. Combining of two or more of any obstacles is acceptable.

2. **Prohibited obstacles:** Tarps, water obstacles with slick bottoms, PVC pipe used as a jump or walk over, tires, rocking or moving bridges, logs or poles elevated in a manner that permits such to roll in a dangerous manner. Animals (live or stuffed) should only be used which would normally be encountered in an outdoor setting and which are not used in an attempt to "spook" a horse.

3. Mandatory obstacles or maneuvers:

1. **Ride over obstacles on the ground** – usually logs or poles. It is recommended that all three gaits (walk, trot, lope) be used, however only two gaits are required.

a) **Walk-Overs.** Walk over no more than five logs or poles. The space between logs for walk-overs should be 20 – 24" apart and no more than 10" high. These can also be in a straight line, curved, zigzagged or raised.

b) **Trot-Overs.** Trot over no more than five logs or poles. The space between trot-overs should be 36-42". Poles may be elevated a maximum of 10". These can also be in a straight line, curved, zigzagged or raised.

c) **Lope-Overs.** Lope over no more than five poles. The space between lope-overs should be 6' to 7'. Poles may be elevated a maximum of 10 ". These can also be in a straight line, curved, zigzagged or raised.

2. **Opening, passing through, and closing gate.** A gate should be used that will not endanger horse or rider and requires minimum side passing.

3. **Ride over wooden bridge.** (Suggested minimum width shall be 36" wide and at least six feet long). Bridge should be sturdy, safe and negotiated at a walk only. Heavy plywood lying flat on the ground is an acceptable simulation of a bridge.

4. **Backing obstacles** – Backing obstacles are to be spaced a minimum of 28" spacing. If elevated, 30" spacing is required. Back through and around at least three markers. Back through L, V, U, straight or similar shaped course. May be elevated no more than 24".

5. Side pass obstacle – Any object which is safe and of any length may be used to demonstrate responsiveness of the horse to leg signals. Raised side pass obstacles should not exceed 12 “.

6. Rope drag – For Open, Non-Pro, LTD Non Pro and Green Horse Classes ONLY. A rope drag is not to be used in Novice or Youth classes. Drag must be a complete figure eight and may begin either direction.

7. Green Horse - Distances may be adjusted for green horses only, if so desired.

4. Optional obstacles: New obstacles may be added at any time, we welcome any new and different tests which members may come up with provided they can be found in everyday ranch work. Following is a list of optional obstacles from which selections can be made, but not limited to: 1) Jump - An obstacle whose center height is not less than 14” high or more than 24” high. Holding the saddle horn is permissible for this obstacle, 2) Carry object from one part of the arena to another, 3) Remove and replace materials from mailbox, 4) Trot through cones – spacing to be minimum of 6’, 5) Cross Natural ditches or up embankments, 6) Swing rope – throw rope at dummy steer head. 7) Step in and out of obstacle, 8) Put on slicker or coat, 9) Stand to mount with mounting block, 10) Walk over water obstacle, 11) Open gate on foot, 12) Pick-up feet, 13) Walk through brush, 14) Ground Tie, or 15) Lead at the trot

C. Scoring Stock Horse Trail

The rider has the option of eliminating an obstacle and taking a score of “0” for the missed obstacle. A judge may ask a horse to pass on an obstacle after three refusals or for safety concerns.

Trail Credits:

- + Credit is given to horses negotiating the obstacles with style and some degree of speed, providing correctness is not sacrificed.
- + Horse should receive credit for showing attentiveness to obstacles and capability of picking their own way through the course when the obstacles warrant it, and willingly responding to the rider’s cues on more difficult obstacles.
- + Quality of movement and cadence should be part of the maneuver score for the obstacle.

Trail Deductions:

Minor Deductions-

- Artificial appearance and/or unnecessary delay while approaching or going through obstacles.
- Each tick of an obstacle
- Break of gait at walk or jog
- Placing both front or hind feet in a single-strided slot or space
- Skipping over or failing to step into a required space
- Split pole in lope-over
- Stepping on a log, pole, cone or obstacle

Major Deductions

- Wrong lead or breaking gait at lope
- Stepping outside the confines of; falling off or out of an obstacle such as a back thru, bridge, side pass, box, or water box
- Refusals, balk, or attempting to evade an obstacle by shying or backing
- Blatant disobedience (kicking out, bucking, rearing, striking)
- Failure to ever demonstrate correct lead or gait, if designated
- Failure to complete obstacle

EV-230 ASHA Stock Horse Reining Class

This class measures the ability of the western stock horse to perform many basic handling maneuvers. The American Stock Horse Association has five recognized regular patterns plus two Novice & Youth Patterns. The patterns are broken down into either 7 or 8 maneuvers to be scored a maximum of 10 points each.

A. These maneuvers include:

Stops

Stops are the act of slowing the horse from a lope to a stop position by bringing the hind legs under the horse in a locked position sliding on the hind feet. The horse should enter the stop position by bending the back, bringing the hind legs further under the body while maintaining forward motion and ground contact and cadence with front legs. Throughout the stop, the horse should continue in a straight line while maintaining ground contact with the hind feet

Spins

Spins are a series of 360-degree turns, executed over a stationary(inside) hind leg. Propulsion for the spin is supplied by the outside rear leg and front legs and contact should be made with the ground and a front leg. The location of hindquarters should be fixed at the start of the spin and maintained throughout the spins.

Rollbacks

Rollbacks are the 180 degree reversal of forward motion completed by running to a stop, rolling(turning) the shoulders back to the opposite direction over the hocks and departing in a canter, as one continuous motion. There should be no hesitation; however a slight pause to regain footing or balance should not be deemed hesitation. The horse should not step ahead or backup prior to rolling back.

Circles

Circles are maneuvers at the lope, of designated size and speed, which demonstrate control, willingness to guide and degree of difficulty in speed and speed changes. Circles must at all times be run in the geographical area of the arena specified in the pattern description and must have a common center point. There must be a clearly defined difference in the speed and size of a small, slow circle and a large, fast circle and the speeds to the left and right should be consistent.

Backups

A backup is a maneuver requiring the horse to be moved in a reverse motion in a straight line a required distance, at least 10 feet.

Hesitate

To hesitate is the act of demonstrating the horse's ability to stand in a relaxed manner at a designated time in a pattern. In a hesitation, the horse is required to remain motionless and relaxed. Reining patterns require a hesitation at the end of the patten to demonstrate to the judge(s) the completion of the pattern

Lead Changes

Lead changes are the act of changing the leading legs of the front and rear pairs of legs, at a lope, when changing the direction traveled. The lead change must be executed at a lope with no change of gait or speed and be performed in the exact geographical position in the arena specified in the pattern description. The change of front and rear leads must take place within the same stride to avoid deductions.

Run Downs and Run-arounds

Run downs are runs through the middle of the arena, and runs along the side and ends of the arena. Run downs and run-arounds should demonstrate control and gradual increase in speed to the stop.

B. Scoring Stock Horse Reining

Credits: + Overall smoothness of pattern

+ Degree of difficulty exhibited by stops, spins and rollbacks and speed in circles and run-outs.

+ Horse should guide willingly without undue resistance.

+ Lack of set-ups or anticipations in the execution of any of the maneuvers.

+ Exhibiting finesse, attitude, quickness, authority and controlled speed while completing a correct maneuver

Deductions: to be subtracted from maneuver scores are as follows

Five Point Deductions:

1. Blatant disobediences , including kicking, bucking or rearing.

2. Spurring in front in cinch or the use of either hand to instill fear or praise.

Two Point Deductions:

1. Break of Gait
2. Freeze up in spins or rollbacks. A freeze up is any time the lateral movement of horse's shoulders is completely stopped and has to be restarted to complete the maneuver.
3. In trot in patterns, failure to stop or walk before executing a canter departure.
4. In run in patterns, failure to be at a canter before first marker
5. Failure to completely pass a specified marker before initiating a stop.
6. Using two hands on a curb bit or using more than one finger between split reins or any finger between romal reins will result in a two point run content deduction each time there is a violation. The free hand may be used to straighten excess rein at any place a horse is allowed to be completely stopped during a pattern.
7. Over or under spinning of more than one-fourth turn
8. Jogging more than two strides to start circles or exit rollbacks.

One point Deduction:

1. Each time a horse is out of lead. Penalties are cumulative for each occurrence and each one-fourth circle.

One-half point Deduction:

1. Jogging less than two strides to start circles or exit rollbacks.
2. Failure to maintain a minimum of twenty feet from wall or fence for stops or rollbacks on standard patterns with the exception of Novice & Youth Pattern # 1.
3. For one stride delayed lead change

EV-240 ASHA Stock Horse Working Cow Horse Class

A versatile western stock horse must also be a cow horse and this class has been designed to demonstrate and measure the horse's ability to do cow work. Holding the saddle horn is permitted in this class. Timing will be done by the announcer. At the end of the time limit, the announcer will call time. If the time has not elapsed and the judge is satisfied that all requirements of the class have been met, the judge should blow the whistle for the contestant to quit work.

The judge may blow a whistle at any time for the contestant to cease work for safety reasons. Judges will give credit for what they have seen. Only the judge may award a new cow to a contestant to replace a cow that will not honor a horse. Contestants must continue working until time is called to avoid a run content deduction.

A. Working Cow Horse Class for Open and NonPro Divisions

There will be a 3 minute time limit per horse to perform the entire work beginning when the cow is turned into the arena. When there is one minute left on the time, the announcer will announce, "one minute". At 3 minutes, the announcer will call time. The work in the open and non-pro cow horse class will consist of the following three parts.

Part One – Boxing the Cow – The rider shall ride into the arena and face the cattle entry gate. The rider shall signal for their cow to be turned into the arena. Upon entry into the arena, the cow shall be controlled on the entry end of the arena for a sufficient amount of time to demonstrate the horse's ability to "hold" the cow. If the cow does not immediately challenge the horse, the rider shall aggressively move in on the cow to demonstrate his horse's ability to drive and block the cow on the entry fence.

Part Two – Fence Work – After the cow has been controlled on the end of the arena, the rider shall deliberately release the cow and drive it down the side of the arena. The cow should be turned on the fence at least once in each direction. The first run out for a turn shall be past the half-way mark of the arena. All turns down the side shall be completed before reaching the end fence.

Part Three – Optional Roping or Circling For the third part of this class, the rider has the option to either rope and stop the cow or to take the cow to the middle of the arena and circle it at least once each direction. A rider may circle or rope the cow, but cannot combine the two to get credit for this portion of the class.

To rope the cow, the rider must be carrying a rope when the class starts. The rider may pull up after the fence work, take down the rope, and proceed to rope and stop the cow. The rider may only throw two loops. A no catch does not mean a score of zero

for this portion of the class. A horse must be given credit for rating and tracking, but should not be scored higher than a horse that has also demonstrated the ability to stop and hold the cow.

B. Scoring Open and NonPro Working Cow Horse Class

Scoring for the working cow horse class shall be 20 points for each of the three parts of the class with a total of 60 points for the entire class. Each of the three parts of the class is broken into two scores of 10. In selecting tie-breakers, a judge may use 1.2.3.4.5.6 in any order. Scoring columns 5 and 6 for both circling and roping may be given any tie breaker rankings, but should be given the same tie breaker rankings. In other words, give only 6 tie breaker rankings with circling and roping scoring columns being the same.

1. Scoring for Part One – Boxing (Maximum of twenty points)

- a. The horse will be scored 10 points for control, position and correctness
- b. The horse will be scored 10 points for degree of difficulty, amount of work done, eye appeal and cow sense.

Credits: + Expression by the horse and making moves with little rider assistance
+ Holding and controlling the cow
+ Amount of work actually done and the degree of difficulty of the work
+ Horse forces cow to turn

Deductions: - Missing cow badly on turns
- Horse having to be handled excessively
- Letting cow escape to start rundown instead by being held, released, and driven down the fence
- Using side fences to turn cow

2. Scoring for Part Two – Fence Work (Maximum of twenty points)

- a. The horse will be scored 10 points for control, position and correctness
- b. The horse will be scored 10 points for degree of difficulty, amount of work done, eye appeal and cow sense.

Credits: + First run at least ½ length of arena
+ Turns that are right on the cow
+ Controlling a difficult cow

Deductions: -Making first run less than ½ length of arena
-Using end fences to help turn cow
-Going around the end of arena to get a turn
-Sliding by cow by more than a horse length on turns

3. Scoring for Part Three – Optional Circling or Roping (Maximum of twenty points)

Circling

- a. The horse will be scored 10 points control, position and correctness
- b. The horse will be scored 10 points for degree of difficulty, amount of work done, eye appeal and cow sense.

Credits: +Getting up on cow close enough to control the circles
+Acknowledging the cow during circling and working willingly

Deductions: -Lack of control in circles due to distance from cow
-Not acknowledging the cow or simply lack of horse's ability

Roping

- a. The horse will be scored 10 points for rating, position, stop and holding.
- b. The horse will be scored 10 points for speed, degree of difficulty, eye appeal and cow sense.

Credits: +Rating and following cow to allow roper the optimum position to rope
+Stopping hard and staying in the ground during the jerk

Deductions: -Not tracking, not rating and not catching up to the cow
-Poor stop

C. ASHA Working Cow Horse Class for LTD Non Pro and Green Horse Divisions

This class has been developed for non-pro riders and the green horse division as an intermediate level working cow horse class. There will be a two minute time limit per horse to perform the entire work beginning when the cow is turned into the arena.

When there is one minute left on the time, the announcer will announce, "one minute". At 2 minutes, the announcer will call time. The work in this class will consist of the following three parts.

Part One – Boxing the Cow – The rider shall ride into the arena and face the cattle entry gate. The rider shall signal for their cow to be turned into the arena. Upon entry into the arena, the cow shall be controlled on the entry end of the arena for a sufficient amount of time to demonstrate their horse's ability to "hold" the cow.

Part Two - Release cow and Drive down Side of Arena to Opposite End of Arena

After the cow has been controlled on the entrance end of the arena, the rider shall deliberately release the cow and set up for driving down the side of the arena. When coming out of corner, the horse shall be close enough to cow to demonstrate control with cow against the fence. This distance and control should be maintained for approximately three-fourths length of arena. Rider will then back horse off of cow and move horse toward center of arena to set cow up for boxing.

Part Three – Boxing the Cow at Opposite end of arena –The exhibitor will again control or "hold" the cow at this end of the arena to demonstrate the horse's ability to "hold" the cow. Continue boxing until time expires.

D. Scoring Working Cow Horse class for Limited Non Pro and Green Horse Divisions

Scoring for the working cow horse class for limited non pro and green horse divisions will be 1 to 50 points based on 20 points for each "boxing the cow" work and 10 points for the drive down the side of the arena. Each of the three parts of the class is broken into two scores. In selecting tie breakers, a judge may use 1 through 6 of the scoring columns in any order.

1. Scoring for Part One – Boxing (Maximum of 20 points)

- a. The horse will be scored 10 points for control, position and correctness.
- b. The horse will be scored 10 points for degree of difficulty, amount of work done, eye appeal and cow sense.

Credit +Expression by the horse and making moves with little rider assistance
+Holding and controlling the cow
+Amount of work actually done and the degree of difficulty of the work

Deductions: -Missing cow badly on turns
-Horse having to be handled excessively
-Letting cow escape to start rundown instead of being held, released, and driven down the fence of arena
- Using side fences to turn cow

2. Scoring for Part Two – Driving down arena fence (Maximum of 10 points)

To receive full credit for the drive down the cow must be controlled on the fence for at least three - fourths the length of the arena.

- a. The horse will be scored 5 points for control, position and initiative.
- b. The horse will be scored 5 points for degree of difficulty, amount of work done, eye appeal and cow sense.

Credit: +Rating the cow
+ Blocking the cow with pressure towards the end of the arena.
+ Driving the cow with control down the side of the arena

Deductions: -Unable to direct cow to opposite end of arena
-Failure to rate the cow and drive against the fence
-Letting cow return to entry gate

3. Scoring for Part Three – Boxing (Maximum of 20 points)

- a. The horse will be scored 10 points for control, position and correctness.
- b. The horse will be scored 10 points for degree of difficulty, amount of work done, eye appeal and cow sense.

Credit: +Expression by the horse and making moves with little rider assistance
+Holding and controlling the cow
+Amount of work actually done and the degree of difficulty of the work

Deductions: -Missing cow badly on turns
-Horse having to be handled excessively
-Letting cow escape

- Credit:** + Expression by the horse and making moves with little rider assistance
+ Holding and controlling the cow
+ Amount of work actually done and the degree of difficulty of the work
- Deductions:** - Missing cow badly on turns
- Horse having to be handled excessively
- Letting cow escape

EV 300 Special Events

2012 American Stock Horse Association

3 Year Old Versatility Futurity World Championship

Purpose and History:

In keeping with the concept of a four event, versatile stock horse, ASHA has developed the three year old futurity event. This event provides an opportunity to showcase the talents of the four event horse at an early age, as well as providing a logical measure of progress for the training of the young stock horse.

Available to ASHA members in good standing, this is an age specific event, open to three year old horses of all breeds. Horses are to be shown in four classes and the Champion will be chosen as the highest placing horse in the "all around". These classes will be: Trail, Pleasure, Reining, and Working Cow Horse. Class rules will be the rules governing the Open division as approved by the 2012 ASHA handbook.

General Rules:

- Horse(s) must be shown as a three year old determined by age as of January 1
- Horse(s) will be exhibited in a snaffle bit, bosal, or hackamore on the day of the futurity
- Horse(s) exhibited in the versatility futurity must have an ASHA competition license. See ASHA Rules , GR-100 Competition Licensing Rules and Regulations)
- Rider must be a current member in good standing of the ASHA.
- A horse may be exhibited by only one rider in the futurity, multiple horse and rider combinations are prohibited.
- At futurity, each horse and rider combination will have one opportunity to show in Trail, Pleasure, Reining, and Working Cow Horse. Therefore, there will only be one go.
- The Versatility Champion will be determined by the highest placing horse and rider combination in the four event competition aka the "All Around".
- The All Around Champion will be considered the '3 Year Old Versatility World Champion'
- Jackpot payback for the futurity will be determined according to ASHA Rules and Bylaws EV-190 - ASHA Entry Fees and Paybacks.
- A nomination form must be submitted for each horse and rider combination with nomination fees. All nomination fees will be paid back plus added money to be determined.
- Detailed information on the 2012 ASHA 3 Year Old Versatility Futurity will be available from the ASHA office.

ASHA Stock Horse Reining Pattern # 1

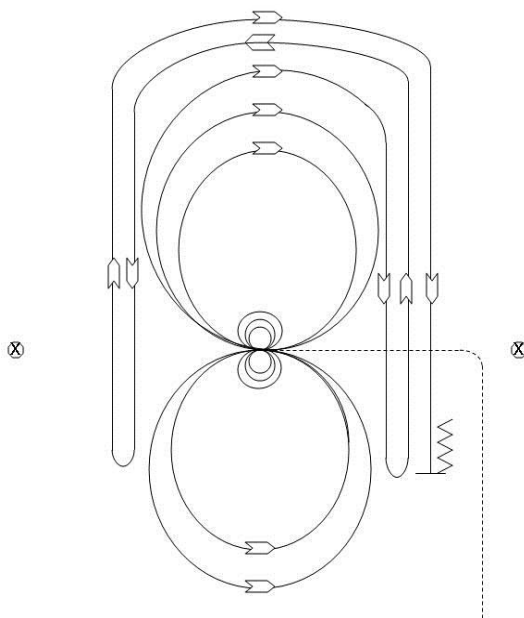

Mandatory Markers:

The judge shall indicate with markers on arena fence the center of the pattern.

Ride pattern as follows:

1. Trot to center of arena and stop.
2. Complete three spins in each direction
3. Begin on right lead and lope two large circles to the right, change leads.
4. Lope two large circles to the left, change leads.
5. Begin a large circle to the right but do not close this circle. Run down the right side of the arena past the center marker and do a left roll back at least 20 feet from the wall or fence, no hesitation.
6. Continue back around the previous circle but do not close this circle. Run down the left side of the arena past the center marker and do a right roll back at least 20 feet from the wall or fence, no hesitation.
7. Continue back around previous circle but do not close this circle. Run down the right side of the arena past the center marker and do a sliding stop at least 20 feet from the wall or fence. Back up at least 10 feet. Hesitate to show completion of pattern.

ASHA Stock Horse Reining Pattern # 2

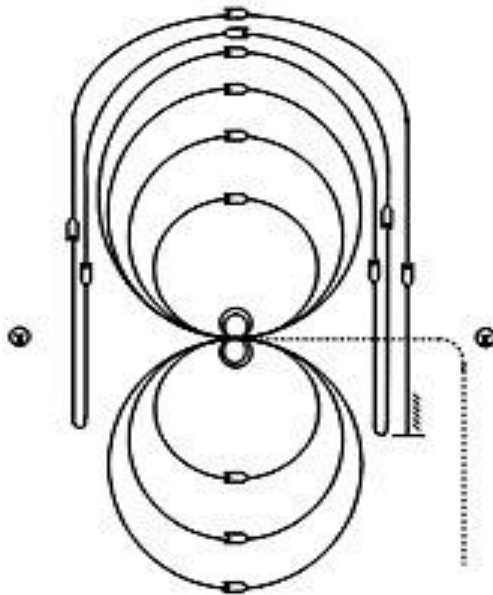

Mandatory Marker along Fence or Wall

The judge shall indicate with markers on arena fence or wall the center of pattern.

Ride pattern as follows:

1. Start by trotting into center of arena and either stop or walk before departure.
2. Make a large fast circle to right on the right lead.
3. Draw the second circle down to a small circle until you reach the center marker; stop.
4. Do four spins to the inside of the small circle at the center marker; at end of spins horse should be facing the left wall, slight hesitation.
5. Begin on left lead and make a large fast circle
6. Then a small circle, again drawing it down to the center of the arena, stop, no hesitation on stops.
7. Do four spins to the inside of the circle, slight hesitation, horse to be facing left wall.
8. Take a right lead & make a fast figure eight over the large circles, close the eight, & change leads.
9. Begin a large fast circle to the right but do not close this circle. Run down the right side of the arena past the marker and do a left roll back at least 20 feet from the wall or fence, no hesitation. Continue back around the previous circle but do not close this circle. Run down the left side of the arena past the center and do a right roll back at least 20 feet from the wall or fence, no hesitation.
10. Continue back around previous circle, but do not close this circle. Run down the right side of the arena past the center marker and do a sliding stop at least 20 feet from the wall or fence. Back up at least 10 feet. Hesitate to show completion of pattern.

ASHA Stock Horse Reining_Pattern # 3

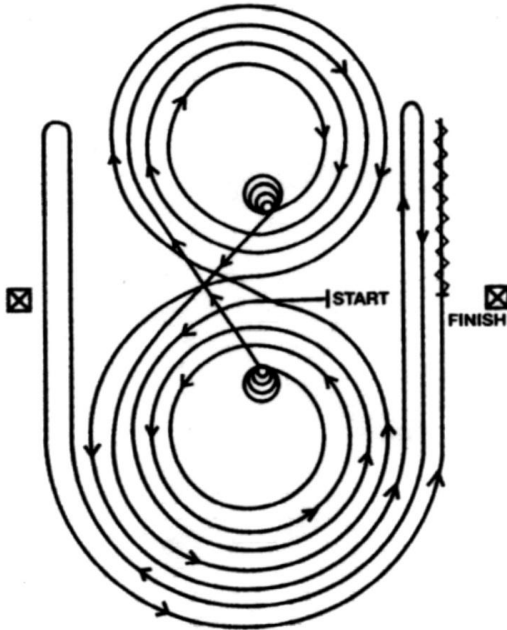

Mandatory Marker along Fence or Wall.

The judge shall indicate with markers on arena Fence or wall the center of pattern.

Ride Pattern as follows:

1. Enter arena at sitting trot. Walk or stop before lope.
Begin at the center of the arena facing the left wall or fence
2. Begin on the left lead and complete three circles to the left. (The first two circles should be large and fast; the third circle small and slow.) Stop at the center of the arena. Hesitate.
3. Complete four spins to the left. Hesitate.
4. Begin on the right lead and complete three circles to the right. (The first two circles should be large and fast; the third circle small and slow. Stop at the center of the arena. Hesitate.
5. Complete four spins to the right. Hesitate.
6. Begin on the left lead and ran a large fast circle to the left, change leads at the center of the arena, run a large fast circle to the right and change leads at the center of the arena.
7. Continue around previous circle to the left but do not close this circle. Run up the right side of the arena past the center marker and do a right rollback at least twenty feet from the wall or fence – no hesitation.
8. Continue around previous circle but do not close this circle. Run up the left side of the arena past the center marker and do a left rollback at least twenty feet from the wall or fence – no hesitation.
9. Continue back around previous circle but do not close this circle. Run up the right side of the arena past the center marker and do a sliding stop at least twenty feet from the wall or fence. Back up at least ten feet. Hesitate to demonstrate completion of the pattern.

ASHA Stock Horse Reining Pattern # 4

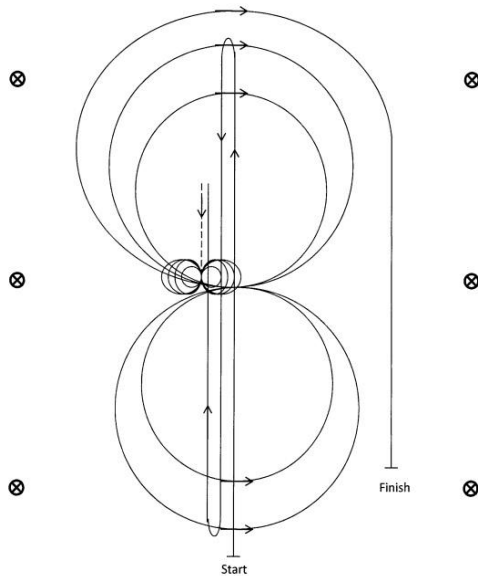

Mandatory Markers along Fence or Wall

The judge shall place markers on arena fence to establish distances.

Ride pattern as follows:

1. Run with speed to the far end of the arena past the end marker and execute a stop followed by a left rollback. (To avoid penalty, the horse must be at a lope when passing the first marker.)
2. Run to the opposite end of the arena past the end marker and do a stop followed by a right rollback.
3. Run past the center marker and do a sliding stop. Back to the center of the arena or at least 10 feet. Hesitate.
4. Complete four right spins.
5. Complete four and 1/4 spins to the left. Horse to be facing the left fence. Hesitate.
6. Beginning on the right lead, complete two circles to the right. The first circle should be large and fast and the second circle small and slow. Change leads at the center of the arena.
7. Complete two circles to the left. The first circle should be large and fast and the second circle should be small and slow. Change leads at the center of the arena.
8. Begin a large fast circle to the right but do not close the circle. Run straight down the right side of the arena past the center marker and do a sliding stop at least twenty feet from the fence. Hesitate to demonstrate completion of pattern.

ASHA Stock Horse Reining_Pattern # 5

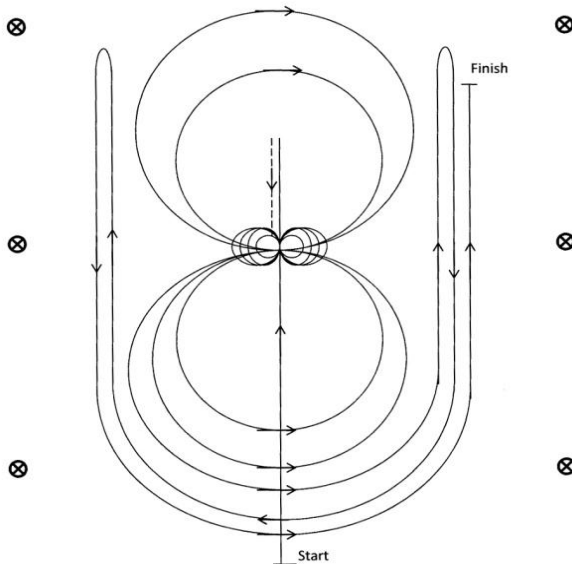

Mandatory Markers along Fence or Wall

The judge shall indicate the area for the pattern with six markers on arena fence.

Ride pattern as follows:

1. RUN past the center marker and do a SLIDING STOP. BACK to center of arena or at least 10 feet. Hesitate. (To avoid penalty, the horse must be loping when passing the first markers.)
2. Complete four RIGHT SPINS.
3. Complete FOUR and 1/4 LEFT SPINS. Horse to be facing left fence at completion. Slight Hesitation.
4. Beginning on the left lead complete TWO CIRCLES to the LEFT. First circle to be small and slow and second circle to be large and fast. CHANGE LEADS at the center of the arena.
5. Complete two CIRCLES to the RIGHT. First circle to be small and slow and second circle to be large and fast. CHANGE LEADS at center of arena.
6. Begin a large fast circle to the LEFT. Do not close this circle. RUN up the right side of the arena past the center marker and at least 20 feet from the fence. Do a RIGHT ROLLBACK.
7. Continue back around the previous circle, but do not close circle. RUN up the left side of the arena at least 20 feet from the fence and past the center marker. Do a LEFT ROLLBACK.
8. Continue back around previous circle. RUN up the right side of the arena at least 20 feet from the fence and past the center marker. do a SLIDING STOP. Hesitate

ASHA Novice and Youth Stock Horse Reining Pattern # 1

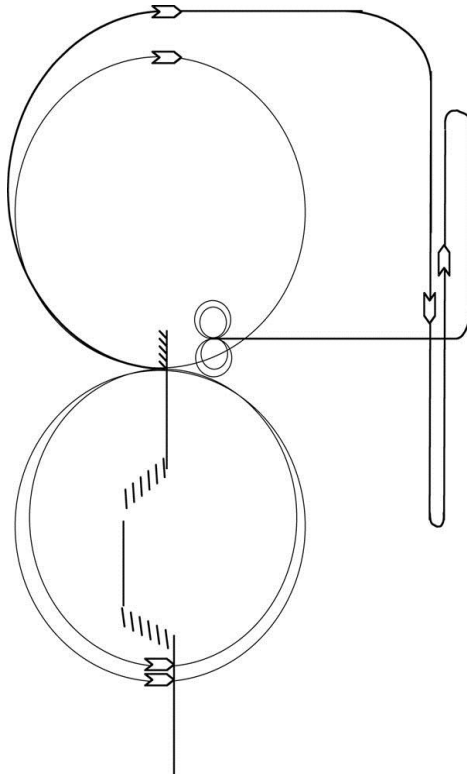

Ride pattern as follows:

1. Enter arena at SITTING TROT
2. TWO-TRACK LEFT, straight TROT, TWO-TRACK RIGHT

[Two-track is moving the horse forward and laterally simultaneously with bit contact. The horse's body is kept pointing straight in the direction indicated with the horse yielding laterally and forward to leg pressure.]

3. Move up to an EXTENDED TROT
4. STOP and BACK; Make left 90 degree PIVOT
5. Begin on right lead and LOPE 1 fast circle
6. CHANGE LEADS; LOPE two fast circles to left
7. CHANGE LEADS; LOPE, beginning a second RIGHT circle
8. Continue circle to wall and LOPE down wall
9. Make LEFT ROLL BACK using wall as assistance
10. LOPE straight down wall; Make RIGHT ROLL BACK using wall as assistance
11. LOPE to middle of arena; STOP
12. Make TWO SPINS EACH DIRECTION
13. Exit arena at a TROT.

ASHA Novice and Youth Stock Horse Reining Pattern # 2

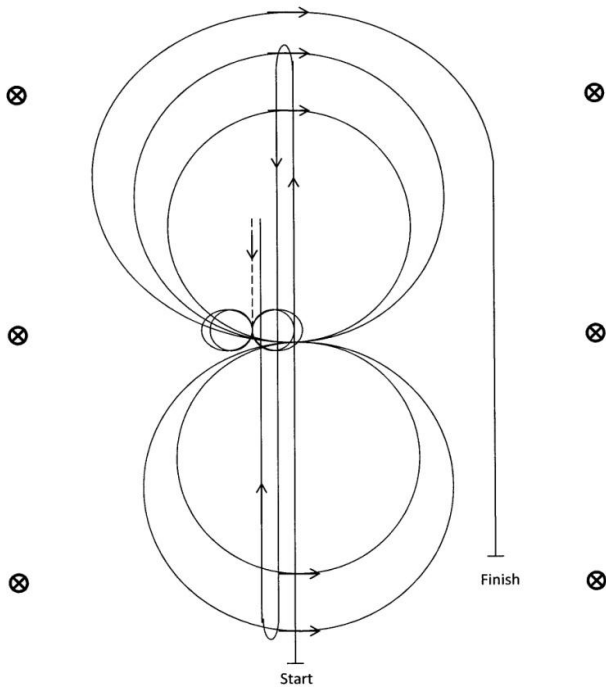

Ride pattern as follows:

1. RUN with speed to the far end of the arena past the end marker. Do a LEFT ROLLBACK. (To avoid a penalty, the horse must be loping when passing the first markers.)
2. RUN to opposite end of arena past the end marker and do a RIGHT ROLLBACK.
3. RUN past the center marker and do a SLIDING STOP. BACK to center of arena or at least 10 feet.
4. Complete TWO RIGHT SPINS
5. Complete TWO and 1/4 LEFT SPINS. Horse to be facing left fence.
6. Beginning on the Right Lead, Complete TWO CIRCLES to the RIGHT. First circle to be large and fast. Second circle to be small and slow. CHANGE LEADS at the center of the arena.
7. Complete two LEFT CIRCLES. First circle large and fast and second circle small and slow. CHANGE LEADS at the center of the arena.
8. Begin a large fast circle to the right, but do not close this circle. RUN straight down the right side of the arena at least 20 feet from fence. RUN past center marker and do a SLIDING STOP. Hesitate.

--NOTES--

American Stock Horse Association
P O Box 3038
Glen Rose, Texas 76043
(254) 898-0906
www.americanstockhorse.org

2012 Officers and Board

| | |
|-----------------------|----------------------|
| President | Dennis Sigler |
| First Vice-President | Tommy Fuller |
| Second Vice-President | Joby Priest |
| Committee Member | Alicia Howard Burton |
| Committee Member | Janet Yeates |
| Past President | B.F. Yeates |
| Executive Director | Vicki Hoggett |

Board Members

Region One Directors and Terms

| | |
|-------------------|-----------|
| Patti Colbert, TX | 2010-2012 |
| Tom Neel, TX | 2012-2014 |
| Brian Sumrall, TX | 2012-2014 |

Region Two Director and Term

| | |
|--------------------|-----------|
| Patrick Kayser, TN | 2012-2014 |
|--------------------|-----------|

Region Five Director and Term

| | |
|---------------------|-----------|
| Kimberlee Gabel, CO | 2012-2014 |
|---------------------|-----------|

ASHA Founding Sponsor



P O Box 469
2487 FM 1119
Centerville, Texas 75833